

Differential pressure sensor Air

Differential pressure transmitter with 8 selectable ranges and Modbus functionality. For monitoring over-, under or the differential pressure of air and other non-flammable and non-aggressive gases. Typical application in HVAC systems for monitoring air filters, fans V-belts or fire and smoke control dampers. Options available with LCD display. NEMA 4X / IP65 rated enclosure.



5-year warranty

Type Overview

Type	Measuring range pressure [Pa]	Measuring range pressure [Inch WC]	Communication	Output signal active pressure	Output signal active volumetric flow	Burst pressure	Display type
22ADP-556	0...7000	0...28	Modbus RTU	0...5 V, 0...10 V	0...5 V, 0...10 V	160 inch WC [40 kPa]	-
22ADP-556L	0...7000	0...28	Modbus RTU	0...5 V, 0...10 V	0...5 V, 0...10 V	160 inch WC [40 kPa]	LCD

Technical data

Electrical Data	Nominal voltage	AC/DC 24 V
	Nominal voltage range	AC 19...29 V / DC 15...35 V
	Power consumption AC	4.3 VA
	Power consumption DC	2.3 W
	Electrical connection	Pluggable spring loaded terminal block max. 2.5 mm ²
	Cable entry	Cable gland with strain relief 2 x Ø6 mm (1/2" NPT conduit adapter included)
Data bus communication	Communication	Modbus RTU
	Number of nodes	Modbus see interface description
Functional Data	Sensor Technology	piezo measuring element
	Application	air
	Multirange	8 measuring ranges selectable
	Voltage output	2 x 0...5 V, 0...10 V, min. resistance 10 kΩ
	Output signal active note	Output 0...5/10 V selectable with switch
	Display	LCD, 1.14x1.38 in. [29x35 mm] With backlight Measured values: Pa, inch WC (programmable) Measured values volumetric flow: m ³ /h, cfm (parametrisable)
	Response time	adjustable 0.8 s or 4.0 s
Measuring Data	Measured values	Differential pressure
	Measuring fluid	air and non-aggressive gases

Measuring Data	Measuring range pressure settings	Setting	Range [Pa]	Range [inch WC]	Factory setting
		S0	0...7000	0...28	✓
		S1	0...5000	0...20	
		S2	0...4000	0...16	
		S3	0...3000	0...12	
		S4	0...2500	0...10	
		S5	0...2000	0...8	
		S6	0...1500	0...6	
		S7	0...1000	0...4	
	Accuracy pressure	measuring range ≤8 inch WC: ±0.04 inch WC measuring range >8 inch WC: ±0.1 inch WC			
	Long-term stability	±2.5% FSO (Full Scale Output) / 4 yr.			
Materials	Cable gland	PA6, black			
	Housing	Cover: PC, orange Bottom: PC, orange Seal: NBR70, black UV resistant			
Safety Data	Protection class IEC/EN	III, Safety Extra-Low Voltage (SELV)			
	Power source UL	Class 2 Supply			
	Degree of protection IEC/EN	IP65			
	Degree of protection NEMA/UL	NEMA 4X			
	Enclosure	UL Enclosure Type 4X			
	EU Conformity	CE Marking			
	Certification IEC/EN	IEC/EN 60730-1 and IEC/EN 60730-2-6			
	Quality Standard	ISO 9001			
	UL Approval	cULus acc. to UL60730-1A/-2-6, CAN/CSA E60730-1			
	Mode of operation	Type 1			
	Rated impulse voltage supply	0.8 kV			
	Construction	Independently mounted control			
	Pollution degree	3			
	Ambient humidity	Max. 95% RH, non-condensing			
Ambient temperature	-10...50°C [15...122°F]				
Fluid temperature	-10...50°C [15...122°F]				

Safety Notes

This device has been designed for use in stationary heating, ventilation and air-conditioning systems and must not be used outside the specified field of application. Unauthorized modifications are prohibited. The product must not be used in relation with any equipment that in case of a failure may threaten humans, animals or assets.

Ensure all power is disconnected before installing. Do not connect to live/operating equipment.

Only authorized specialists may carry out installation. All applicable legal or institutional installation regulations must be complied during installation.

The device contains electrical and electronic components and must not be disposed of as household refuse. All locally valid regulations and requirements must be observed.

Remarks

Manual zero-point calibration

In normal operation zero-point calibration should be executed every 12 months.
 Attention! For executing zero-point calibration the power supply must be connected one hour before.

- Release both connection tubes from the pressure terminals + and -
- Press the button until the LED lights permanently
- Wait until the LED flashes again and reinstall the connection tubes to the pressure ports (note + and -)

Operating controls and indicators

Indicator elements

Depending on the device and the number of measured values, the display automatically scales. Parameters, such as the fading in/out of measured values, brightness and traffic light function, are changed via the app or bus system. During the boot process, the software and hardware versions are displayed.

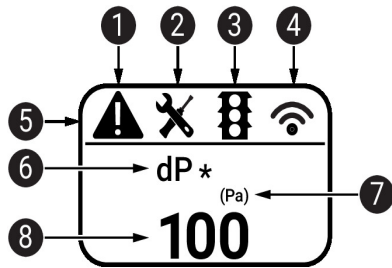

- 1 Fault / sensor failure
- 2 Service / visual inspection due
- 3 TLF (traffic light function) active (thresholds for display colour changes)
- 4 Radio active (not available)
- 5 Status bar
- 6 Measured value (* appears when TLF function is activated for this value)
- 7 Unit of measure
- 8 Measured value

Scope of delivery

Scope of delivery

Description	Type
Mounting plate L housing	A-22D-A10
Duct connector kit, PVC tube 2 m, 2 connection elements (Plastic) for 22ADP-..	A-22AP-A08
Cable Gland with strain relief Ø6...8 mm	
Dowel	
Screws	
1/2" NPT conduit adapter, 2 x Ø6 mm	

Accessories

Optional accessories

Description	Type
Pitot tube, Metal, L 1.5", Tube connection 0.2"	A-22AP-A01
Pitot tube, Metal, L 4", Tube connection 0.2"	A-22AP-A03

Tools

Description	Type
Belimo Duct Sensor Assistant App	Belimo Duct Sensor Assistant App
Bluetooth dongle for Belimo Duct Sensor Assistant App	A-22G-A05
* Bluetooth dongle A-22G-A05	
Certified and available in North America, European Union, EFTA States and UK.	

Service

Service tools connection This sensor can be operated and parametrized using the Belimo Assistant App. When using the Belimo Duct Sensor Assistant App, the Bluetooth dongle is required to enable communication between the app and the Belimo sensor.

For the standard operation and parametrization of the sensor the Bluetooth dongle and the Belimo Duct Sensor Assistant App are not needed. The sensor will arrive pre-configured with the factory default settings shown above.

Requirement:

- Bluetooth dongle (Belimo Part No: A-22G-A05)
- Bluetooth-capable smartphone
- Belimo Duct Sensor Assistant App (Google Play & Apple App Store)

Procedure:

- Plug the Bluetooth dongle into the sensor via the Micro-USB connector or by means of the interface PCB
- Connect Bluetooth-capable smartphone with Bluetooth dongle
- Select parametrization in the Belimo Assistant App

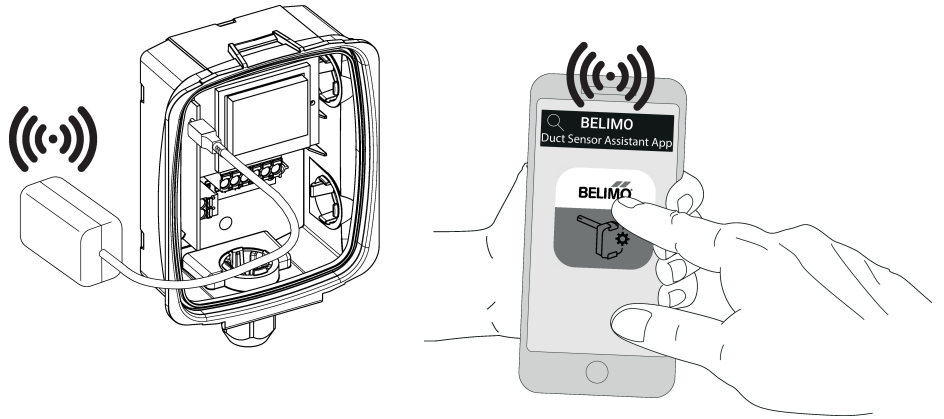

Wiring Diagram

Notes Supply from isolating transformer.



The wiring of Modbus RTU (RS-485) is to be carried out in accordance with applicable regulations (www.modbus.org). The device has switchable resistors for bus termination.

Modbus-GND: Supply and communication are not galvanically isolated. Connect earth signal of the devices with one another.

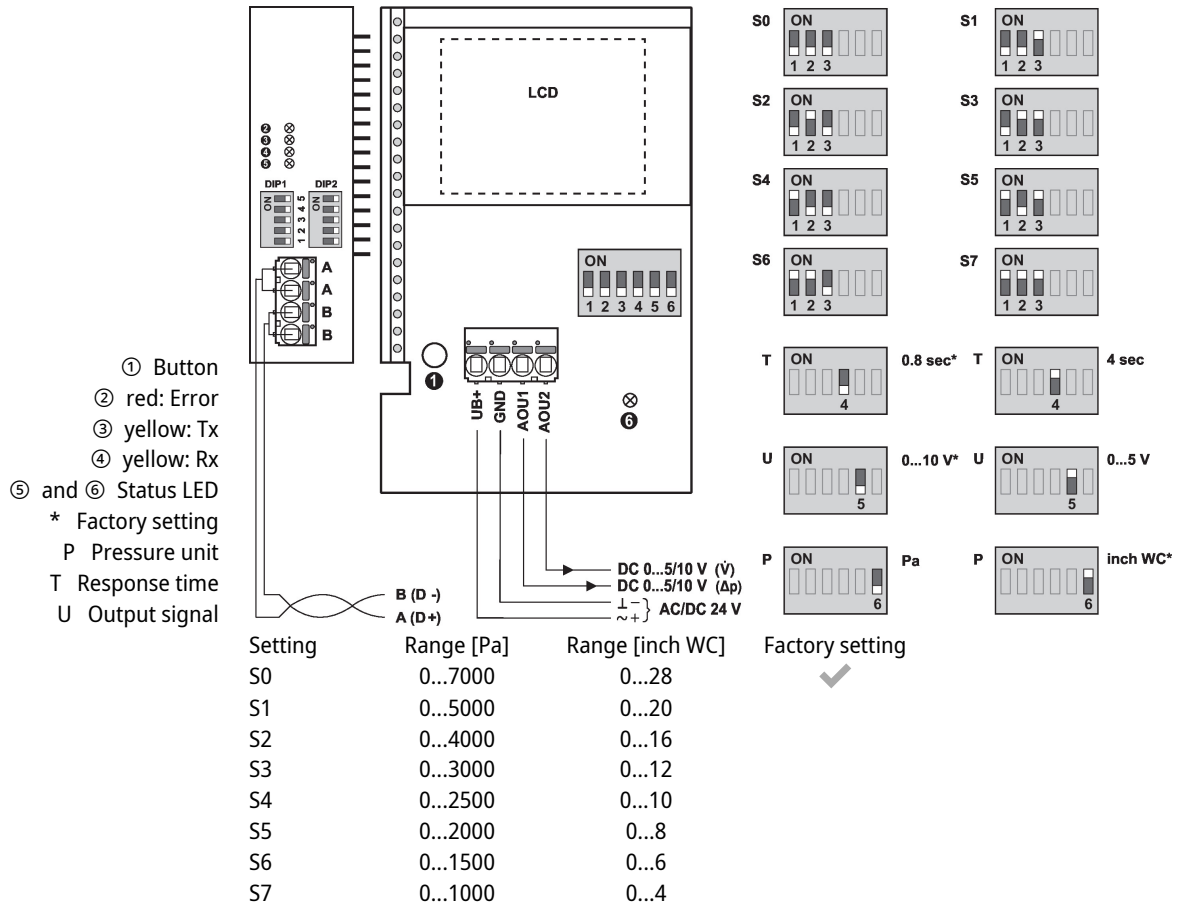

Detailed documentation

The separate document Sensor Modbus-Register informs about Modbus register, addressing, parity and bus termination (DIP1: address, DIP2: baud rate, parity, bus termination)

In addition to the information on the bus, the following analog outputs are available:

AOU1: differential pressure

AOU2: volumetric flow

The volumetric flow is calculated from the differential pressure, the k-factor and the height.

Factory setting for the k-factor is 1.00 and for the height 330 metres above sea level.

The values of the k-factor and the height can be changed via bus system.

Wiring RS485 Modbus RTU

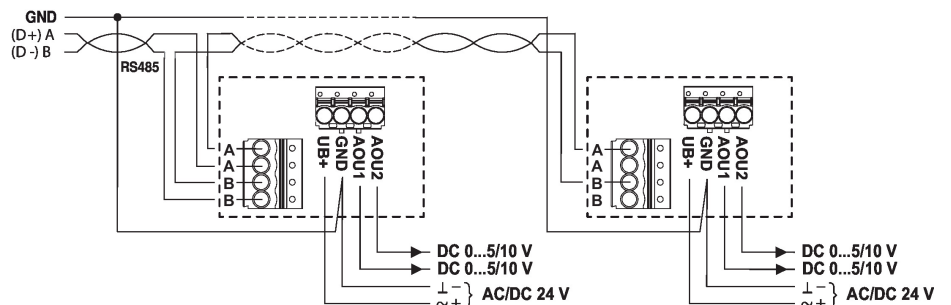

Dimensions

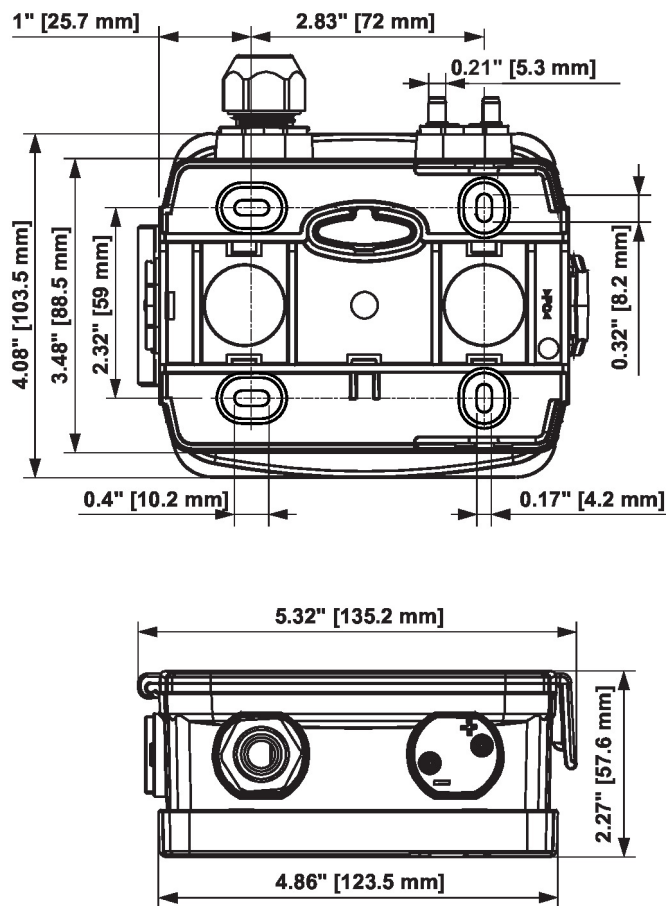

Type	Weight
22ADP-556	0.90 lb [0.41 kg]
22ADP-556L	0.95 lb [0.43 kg]