



5-year warranty



MFT

Technical data

| | | |
|------------------------|------------------------------------|---|
| Electrical data | Nominal voltage | AC/DC 24 V |
| | Nominal voltage frequency | 50/60 Hz |
| | Nominal voltage range | AC 19.2...28.8 V / DC 19.2...28.8 V |
| | Power consumption in operation | 13 W |
| | Power consumption in rest position | 1.5 W |
| | Transformer sizing | 18 VA |
| | Electrical Connection | 18 GA plenum cable, 1 m, with 1/2" conduit connector |
| | Overload Protection | electronic throughout full stroke |
| Functional data | Actuating force motor | 100 N [22 lbf] |
| | Operating range Y | 2...10 V |
| | Operating range Y note | 4...20 mA w/ ZG-R01 (500 Ω, 1/4 W resistor) |
| | Input Impedance | 100 kΩ for 2...10 V (0.1 mA), 500 Ω for 4...20 mA, 1500 Ω for On/Off |
| | Operating range Y variable | Start point 0.5...30 V End point 2.5...32 V |
| | Operating modes optional | variable (VDC, on/off) |
| | Position feedback U | 2...10 V |
| | Position feedback U note | Max. 0.5 mA |
| | Position feedback U variable | VDC variable |
| | Direction of motion motor | reversible with switch |
| | Manual override | external push button |
| | Stroke | 1.6...4.0" [40...100 mm] |
| | Running Time (Motor) | 3.5 s / 100 mm |
| | Running time motor variable | 3.5...15 s / 100 mm |
| | Noise level, motor | 35 dB(A) |
| Safety data | Power source UL | Class 2 Supply |
| | Degree of protection IEC/EN | IP54 |
| | Degree of protection NEMA/UL | NEMA 2 |
| | Enclosure | UL Enclosure Type 2 |
| | Agency Listing | cULus acc. to UL60730-1A/-2-14, CAN/CSA E60730-1:02 CE acc. to 2014/30/EU and 2014/35/EU |
| | Quality Standard | ISO 9001 |
| | UL 2043 Compliant | Suitable for use in air plenums per Section 300.22(C) of the NEC and Section 602 of the IMC |
| | Ambient humidity | Max. 95% RH, non-condensing |
| | Ambient temperature | -22...122°F [-30...50°C] |
| | Storage temperature | -40...176°F [-40...80°C] |

| | | |
|--------------------|------------------|------------------|
| Safety data | Servicing | maintenance-free |
| Weight | Weight | 1.6 lb [0.74 kg] |
| Materials | Housing material | UL94-5VA |

Footnotes †Rated Impulse Voltage 800V, Type of Action 1, Control Pollution Degree 2.

Product features

| | |
|------------------------------|--|
| Application | <p>For proportional modulation of dampers in HVAC systems. Actuator sizing should be done in accordance with the damper manufacturer's specifications.</p> <p>The default parameters for 2 to 10 VDC applications of the ...MFT actuator are assigned during manufacturing. If necessary, custom versions of the actuators can be ordered. The parameters can be changed by two means: pre-set and custom configurations from Belimo or on-site configurations using the Belimo PC-Tool software.</p> |
| Operation | <p>The actuator is not provided with and does not require and limit switches, but is electronically protected against overload. The anti-rotation strap supplied with the actuator will prevent lateral movement.</p> <p>The LHQB(X) series provides 4" [100 mm] of linear stroke. The stroke of the gear rack can be adjusted on both sides in increments of 0.8" [20 mm] by means of the mechanical end stops.</p> <p>When reaching the damper or actuator end position, the actuator automatically stops. The gears can be manually disengaged with a button on the actuator cover.</p> <p>The LHQB(X)24-MFT-100 actuators use a sensorless brushless DC motor, which is controlled by an Application Specific Integrated Circuit (ASIC). The ASIC monitors and controls the actuator's rotation and provides a digital rotation sensing (DRS) function to prevent damage to the actuator in a stall condition. Power consumption is reduced in holding mode.</p> |
| Typical specification | <p>Modulating control, electrical fail-safe damper actuators shall be electronic type with integrated linear stroking arm. Actuators must provide modulating control in response to a control input from an electronic controller or positioner. Actuators shall have brushless DC motor technology and be protected from overload at all angles of rotation. Actuators shall have reversing switch and manual override on the cover. Run time shall be constant and independent of torque. A 2 to 10 VDC feedback signal shall be provided for position feedback. Actuators shall be cULus listed, have a 5-year warranty, and be manufactured under ISO 9001 International Quality Control Standards. Actuators shall be as manufactured by Belimo.</p> |

Accessories

| Electrical accessories | Description | Type |
|------------------------|---|----------|
| | DC Voltage Input Rescaling Module | IRM-100 |
| | Convert Pulse Width Modulated Signal to a 2...10 V Signal for Belimo Proportional Actuators | PTA-250 |
| | Positioner for wall mounting | SGA24 |
| | Positioner for front-panel mounting | SGF24 |
| | Cable conduit connector 1/2" | TF-CC US |
| | Gateway MP to BACnet MS/TP | UK24BAC |
| | Gateway MP to LonWorks | UK24LON |
| | Gateway MP to Modbus RTU | UK24MOD |
| | Resistor, 500 Ω, 1/4" wire resistor with 6" pigtail wires | ZG-R01 |
| | Resistor kit, 50% voltage divider | ZG-R02 |
| | Transformer, AC 120 V to AC 24 V, 40 VA | ZG-X40 |
| | Battery backup system, for non-spring return models | NSV24 US |
| | Battery, 12 V, 1.2 Ah (two required) | NSV-BAT |

| Mechanical accessories | Description | Type |
|------------------------|---|---------|
| | Ball joint suitable for damper crank arm KH8 / KH10, Multipack 10 pcs. | KG10A |
| | Ball joint suitable for damper crank arm KH8, Multipack 10 pcs. | KG6 |
| | Ball joint suitable for damper crank arm KH8, Multipack 10 pcs. | KG8 |
| | Push rod for KG6 & KG8 ball joints (36" L, 5/16" diameter). | SH8 |
| | Rotary support, for linear actuator, for compensation of transverse forces | Z-DS1 |
| | 3/8"-16 shaft clevis for AHK/AH. | Z-KSC |
| | Bracket for AHK/AH/LH linear actuators. | ZG-119 |
| Tools | Description | Type |
| | Belimo PC-Tool, Software for adjustments and diagnostics | MFT-P |
| | Signal simulator, Power supply AC 120 V | PS-100 |
| | Connection cable 16 ft [5 m], A: RJ11 6/4 ZTH EU, B: 6-pin for connection to service socket | ZK1-GEN |
| | Connection cable 16 ft [5 m], A: RJ11 6/4 ZTH EU, B: free wire end for connection to MP/PP terminal | ZK2-GEN |
| | Connection cable 10 ft [3 m], A: RJ11 6/4 ZTH EU, B: 3-pin Weidmüller and supply connection | ZK4-GEN |
| | Service Tool, with ZIP-USB function, for programmable and communicative Belimo actuators, VAV controller and HVAC performance devices | ZTH US |

Electrical installation

- Ⓐ Actuators with appliance cables are numbered.
- ⚠️ Provide overload protection and disconnect as required.
- ⚠️ Actuators may also be powered by DC 24 V.
- ⚠️ Only connect common to negative (-) leg of control circuits.
- ⚠️ A 500 Ω resistor (ZG-R01) converts the 4...20 mA control signal to 2...10 V.
- ⚠️ Actuators may be connected in parallel if not mechanically linked. Power consumption and input impedance must be observed.
- ⚠️ IN4004 or IN4007 diode. (IN4007 supplied, Belimo part number 40155).

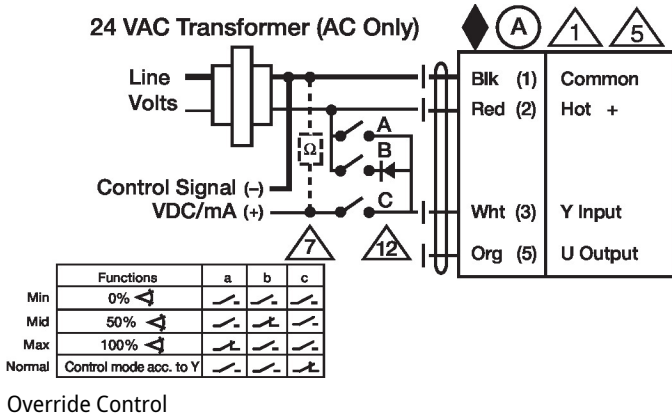

Wiring diagrams

On/Off

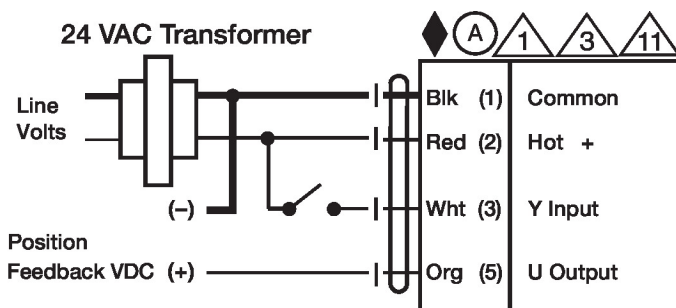

VDC/mA Control

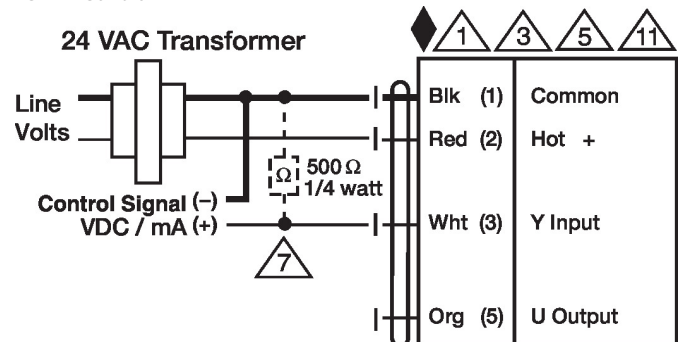

Override Control

24 VAC Transformer (AC Only)

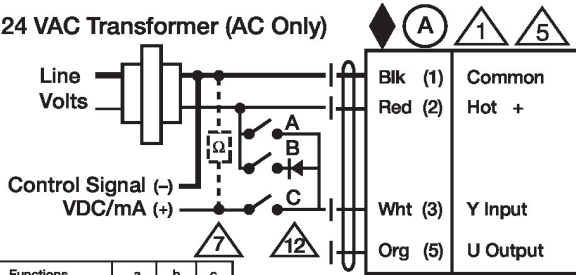

| Functions | a | b | c |
|-----------|------------------------|---|---|
| Min | 0% | | |
| Mid | 50% | | |
| Max | 100% | | |
| Normal | Control mode acc. to Y | | |

Dimensions

