

Model SM906 Series

SUPERPROX[®] Ultrasonic Analog Output Sensors Up to 8 Meter Span Measurement & Level Control

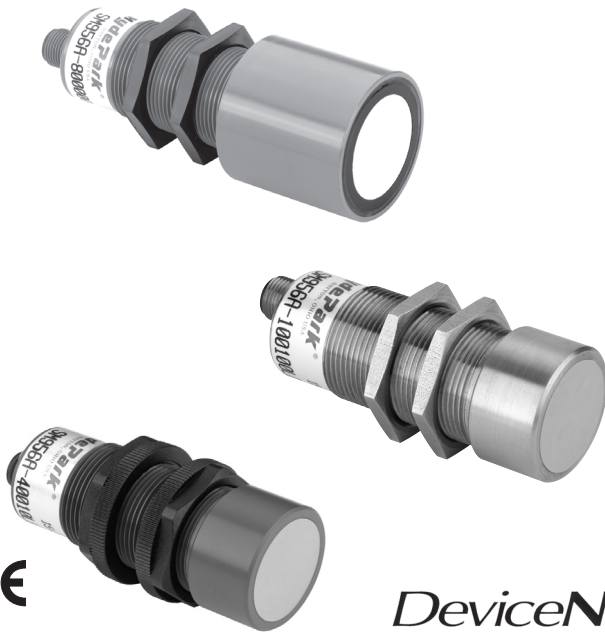

DeviceNet[™]

Control levels and measure distances over spans of up to 8 meters (26 feet) with broad functionality and 30 mm mounting convenience

In vast contrast to other self-contained analog sensors, this new and smaller 30 mm, SUPERPROX[®] Model SM906 sensor series offers mounting convenience, broad functionality, and a selection of three analog sensing spans encompassing a few inches from the sensor to as far away as 26 feet. Depending on the model selected and the distance or level of the material being measured or controlled, the sensors offer analog spans of 1 m (39"), 2 m (79"), and a long span of 8 m (26'). The capability is enhanced further with the shortest deadbands in the sensing industry of 51 mm (2"), 120 mm (4.7"), and 203 mm (8"), respectively.

As shown in the Model Reference Guide, the SM906 series of ultrasonic analog sensors gives the user a wide selection of factory-configurable functionality to maximize the sensor's efficiency in specific analog sensing applications. In addition to the analog sensing span, the user may select a 0 to 10 VDC or 4 to 20 mA output that is either directly or inversely proportional, output state for loss of echo and power up, and re-

sponse time. Also, a broad selection of sensing functionality configurations, with foreground and/or background suppression, makes possible optimum sensing discrimination. This includes, for example, the capability of monitoring levels in a tank while ignoring the paddles on the tank agitator.

The 30 mm housing, up to 60% smaller than other analog sensors with equal functionality, provides a package for the SM906 that is easily installed, without positioning limitations, in covers and other hard-to-mount areas. The models in this series are equipped with a push-button to set the sensors' near and far span limits. When it is impractical to use the push-button for setting the long-range limits, an optional AC441A, hand-held, setup/display accessory is available. The two limits can be set for a span to either encompass the full range of the sensor or create a span as small as desired for precise level or distance control. A typical example of precise level control is when the application calls for maintaining a constant fill level in a filler machine. In this example, the analog output provides a means of controlling the product flow into the filler as the filler speed changes. The analog output may provide a means for controlling the speed of other machinery as well as regulating the movement of control valve

- Sensing spans of 1 m (39"), 2 m (79"), and 8 m (26')
- Easy push-button setup or optional hand-held, setup/display accessory available for all
- Either 4 to 20 mA or 0 to 10VDC analog output; either direct or inverse proportional outputs
- Epoxy sealed in tough ULTEM[®] plastic or stainless steel housing
- Resistant to caustic materials and harsh environments
- Field programmable capability
- DeviceNet capability
- CE certified

actuators. The analog output may also connect directly to programmable controller analog input modules for performing complex loop control or simple status (e.g., distance measuring) monitoring functions. All control limits are stored in nonvolatile memory and thus are retained if power is removed from the sensor.

Unlike other sensing technologies, these sensors are capable of detecting all materials whether, liquid, granular, and solid, and regardless of color, shape, and composition, transparent or opaque, including powder, food products, grains, chemicals, pharmaceuticals, oils, plastics, and objects that change colors. The threaded housings are available in either ULTEM® plastic or SS303 stainless steel which are epoxy encapsulated to withstand shock and vibration. Both housings are sealed to withstand dusty, dirty, clean-in-place, noncondensing humidity, high-pressure washdown environments, and they are virtually unaffected by changing light conditions, colors, and noise. In meeting NEMA 4X (indoor use only) and IP67 industry standards, the sensors resist most acids, bases, and oils, including most food products. All the sensors in this model series are CE certified.

1 meter and 2 meter span models

For purpose of definition, the standard 1 meter span models are identified in the Model Reference Guide as the Model SM906A-1 and SM956A-1 series sensors and the 2 meter-span models are identified as the Model SM906A-4 and SM956A-4 series sensors. Respectively, these models provide for analog output sensing from 50.8 mm to 1 m (2" to 39") and 120 mm to 2 m (4.7" to 79"). The 96 mm (3.78") length of the connector model, excluding the connector/cable assembly, adds to the sensor's installation convenience. Operating on a sonic frequency of 200 kHz, these sensors have a standard response time of 25 ms and 35 ms for the 1 and 2 meter span models, respectively, with others available as shown in the Model Reference Guide. The FDA approved silicone rubber transducer, while used to couple the ultrasonic energy to the air, is also resistant to most acids, bases, oils, and food products.

Various functional choices plus the mounting convenience of a 30 mm housing combine to achieve reliability and cost effectiveness for these models in the detection of moving object positions in specific sensing applications. These include: monitoring and

controlling levels of liquids and solid materials in bins and filler bowls, controlling container flow on mass conveyors, monitoring and controlling roll diameters and speeds, webs of paper and fabrics, extrusion widths, tension, dancer loops and valve positions, as well as the modulation of variable-speed motors, pumps and winding/unwinding equipment.

For 1 meter span analog output sensing applications that require measurement and control capability in severe, corrosive-type environments, the Model SM906A-7STS and Model SM956A-7STS series models have an SS303 stainless steel housing and an SS304 stainless steel-faced transducer. With an analog sensing span of 120 mm to 1 m (4.7" to 39"), these sensors provide reliable operation in the detection of certain chemicals and corrosive materials or where caustic cleaning solutions are used in washdowns of machinery and equipment in close proximity to the sensor. For out-of-doors analog sensing applications, where cold weather is a factor, this corrosion-resistant model series provides reliable operation in temperatures as low as -20°C (-4°F).

8 meter, long-span models

The Model SM906A-8 and Model SM956A-8 series represents the only analog sensors on the market that offer the combination of shortest deadband, longest span, and smallest package. As indicated in the Model Reference Guide, these sensors measure and monitor the position and level of objects over a sensing span of just 203 mm (8") to 8 m (26'). With this shortest deadband, the need to position the sensor at great distances from the object as with most long-span sensors, is eliminated. Only 116.31 mm (4.579") in length for the cable-style model, a fraction of the size of other long-span sensors, these 30 mm diameter sensors are easily mounted in covers and other tight spaces in the plant. They operate on a sonic frequency of 75 kHz with a standard response time of 250 ms and a minimum response time of 150 ms. Other response times are available. An epoxy transducer face, in addition to coupling the ultrasonic energy to the air, allows the sensor to perform in a wide range of harsh environments including those involving most acids, bases, and oils.

By virtue of the 75 kHz frequency, the sensor's wide, 20-degree beam is especially effective in sensing the tank or bin levels of various types of liquids, solids, and granules. This includes ap-

plications involving the blending of ingredients and the processing of food products and pharmaceuticals, as well as the treatment of water and sewage. For outdoor analog output applications, the sensors have temperature compensation for operation in temperatures ranging from -20° to 60°C (-4° to 140°F). In applications where high sound absorption conditions exist in the material being detected, (e.g., tiny plastic pellets) and either the 1 or 2 meter span model sensor becomes unreliable because of lost energy, the more powerful 8m span SM906 can provide the solution when used in the shorter-span distances.

Operation

The Model SM906 series is a self-contained, pulse-echo device that both transmits and receives sonic energy within the specified analog span. Operating on 15 to 24 VDC, these sensors use the latest ultrasonic sensing and microprocessor technology that allows the sensor to ignore all surrounding sonic interference and detect only the designated object.

During operation, the sensor monitors the distance to an object or level while generating a proportional analog output relative to the two analog span limits. When an object is within the analog span, the analog output value changes proportionally in relation to the analog span limits. For example, if the object is halfway between the analog span limits, the output is either 5 volts or 12 mA, depending on the output model selected. The output range adjusts to the size of the analog span and remains proportional regardless of where the limits are set for the analog span.

The sensors are equipped with a multicolor sensing status LED and a amber output LED. The multicolor LED indicates where the level or target position is relative to the span limits. It is green when the object is between the analog span limits, red if closer than the near span limit, and amber if farther than the far span limit. The amber LED indicates the relative value of the analog output and varies in intensity according to the output. The higher the current or voltage output, the brighter the amber LED.

As shown on this page, Hyde Park offers both direct and inverse proportional analog output models for continuous sensing applications.

How does it work?

During setup and operation, these SM906 series ultrasonic sensors continually and accurately measure the elapsed time of every pulse echo reception between each pulse transmission. The transmitted pulse begins a time clock to register the elapsed times for the received pulse echoes. Given the elapsed time, the sensor software calculates the distance traveled out to the object or surface and back to the sensor, using the formula, $D = Tvs/2$, where: D = distance from the sensor to the object; T = elapsed time between the pulse transmission and its echo reception; and Vs = the velocity of sound, approximately 1100 feet per second.

During operation, the calculated distance (D) between the sensor and the object is compared to the distances between the sensor and the analog span limits. These limits are shown in the illustration below as D_{wi} and D_{wo} . If D is within the analog span limits, according to the selected sensing functionality configuration, a proportional output value for D , relative to the analog span limits, is generated.

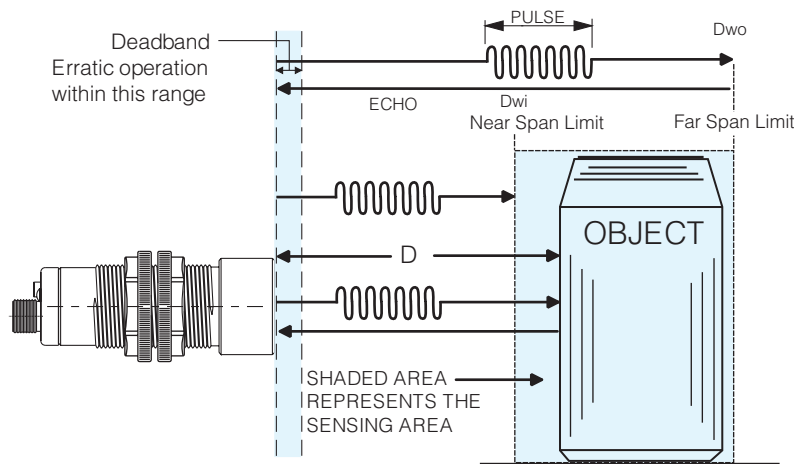

Inverse Proportional Output

The analog 0 to 10 Volt or 4 to 20 mA signal value decreases as the object moves closer to the near span limit.

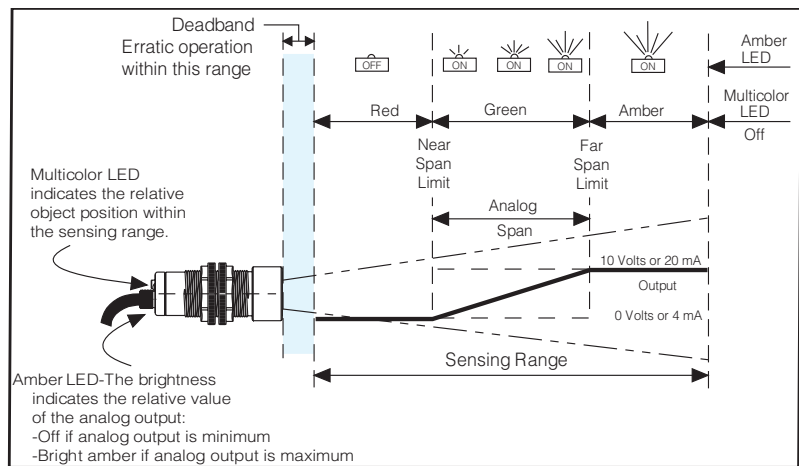

Direct Proportional Output

The analog 10 to 0 Volt or 20 to 4 mA signal value increases as the object moves closer to the near span limit.

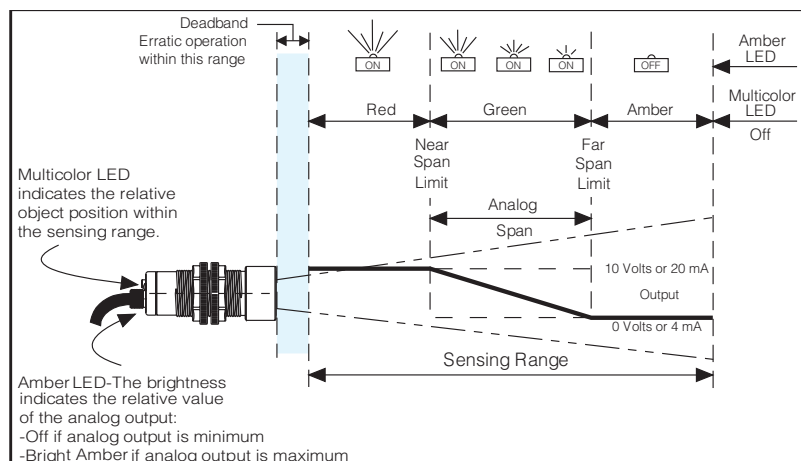

Model Reference Guide - SM906 Series

Use the guide below to ensure the correct model number is specified for the application. Please note that not all sensor model combinations are available.

EXAMPLE MODEL:

SM9 5 6 A - 1 0 0 0 0 0 -

SUPERPROX® Product Series

Power/Connection Type

0...15 to 24 VDC / cable style

5...15 to 24 VDC / connector style

Sensing Function

6...Analog

Design Level

A...Applies to all models

Analog Span

1...51 mm to 1 m (2 to 39")

4...120 mm to 2 m (4.7 to 79")

7...120 mm to 1 m (4.7 to 39") - Required for ST option

8...203 mm to 8 m (8" to 26')

Output Signal

0...Inverse 0 to 10 V

4...Inverse 0 to 5 V

8... Autoslope 0 to 10 V

1...Direct 0 to 10 V

5...Direct 0-5 V

9... Autoslope 4 to 20 mA

2...Inverse 4 to 20 mA

6...Inverse 0 to 20 mA

3...Direct 4 to 20 mA

7...Direct 0 to 20 mA

Output State for Loss of Echo and Power Up

0...Minimum

1...Maximum

2...Hold on loss of echo and minimum on power up

3...Hold on loss of echo and maximum on power up

Response Time

0...Standard: 25 ms (1 m) / 35 ms (2 m) / 250 ms (8 m)

1...Fast: 15 ms (1 m) / 20 ms (2 m) / 150 ms (8 m)

2...100 ms (1 m / 2 m)

3...250 ms (1 m/2 m)

4...500 ms (1 m/2 m/8 m)

5...1.00 s (1 m/2 m/8 m)

6...2.50 s (1 m/2 m/8 m)

Functionality

00...Standard: No foreground or background suppression (background mode)

01...Foreground suppression only (object mode) ignore echoes before near limit

02...Foreground suppression only (background mode), process first echo, ignore if before near limit

03...Foreground and background suppression (background mode), process first echo, ignore if not within limits

Options

...No designator indicates no options

ST...Stainless transducer (available in stainless steel housing for 120 mm to 1 m models only)

FS...Fluorosilicone transducer face (1 m models only)

AD...Limits push-button disabled

Housing Types

...No designator indicates standard ULTEM® plastic housing

S...SS303 stainless steel (1 and 2 m models only)

* ULTEM® is a registered trademark of The General Electric Company.

Field configurable and DeviceNet Model Reference Guides start on page 4-145.

Sensing Functionality Configuration

There are four sensing functionality configurations available, through model selection, to provide a Model SM906 series sensor with optimum sensing discrimination. This means the sensor is capable of detecting objects at certain distances and ignoring objects at other distances. An example would be in the monitoring of a level in a tank while ignoring the paddles on the tank agitator which would be closer than the near span limit.

Each configuration employs a different algorithm to determine which echo returns are either accepted or ignored over the specified sensing range. Thus, these four configurations enable the sensor series to address a multitude of continuous-sensing, process-control applications.

Use the following four illustrations as a guide in selecting the functionality best suited for the sensing application.

Configuration: “00” - Standard: No foreground or background suppression

With this configuration, the sensor processes only the first echo received from anywhere within the sensing span.

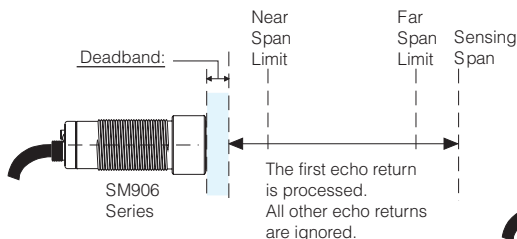

Configuration: “01” - Foreground suppression only (object mode)

With this configuration, the sensor ignores echoes received from objects closer than the near span limit and processes only the first echo received from between the near span limit and the sensing range.

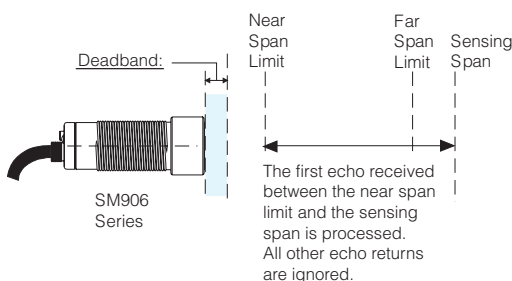

Configuration: “02” - Foreground suppression only (background mode)

With this configuration, the sensor processes only the first echo received from an object. If the first processed echo from the object is closer than the near span limit, the echo is ignored and not processed. If the first processed echo from the object is between the near span limit and the sensing range, the echo is processed and the analog output value is updated.

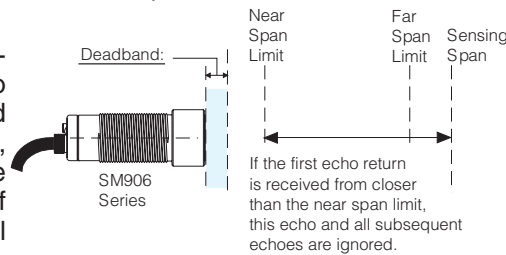

Configuration: “03” - Foreground and background suppression (background mode)

With this configuration, the sensor processes only the first echo received from an object. If the echo is received from between the near and far span limits, the echo is accepted and the analog output value is updated. If the echo is received from closer than the near span limit or farther than the far span limit, the echo is ignored and the analog output value is not updated.

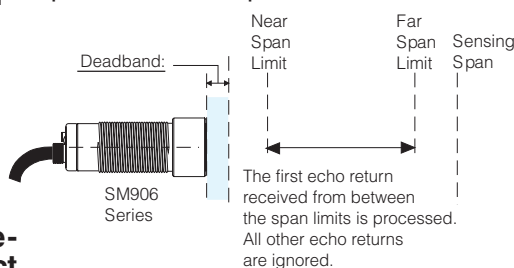

Analog Output Response Function

The analog output value is derived from the sensor response time and the object distance from the sensor. The “standard” response for the one meter range sensing model is 25 ms and its analog output value is derived from the average of the last two echo returns. The “fast” response time for a one meter range sensing model is 15 ms and its analog output value is derived from the last echo return. For sensors with other response times, the analog output value reaches 95% of the final output value in the stated response time using an exponential averaging function.

Setting the Analog Span Limits

Located on the backside of the sensor, the SETUP push-button is used to set both the near and far span limits. Depress the SETUP push-button (the multicolor LED rapidly flashes amber to indicate the push-button is being pressed) until the multicolor LED flashes green in about 3 seconds, and then release the SETUP push-button. The multicolor LED continues flashing green indicating the sensor is waiting for the first span limit. Align a flat object parallel to the sensor face at the desired distance position for either (near or far) span limit, and press the SETUP push-button once. Upon release of the SETUP push-button, the multicolor LED flashes amber indicating the first span limit is set and the sensor is waiting for the second span limit. Align a flat object parallel to the sensor face at the desired position for the second span limit and press the SETUP push-button once. Upon release of the SETUP push-button, the multicolor LED turns to the color that indicates where the object is located. The sensor has no time-out for setting limits.

While the SETUP push-button is depressed, the multicolor LED turns amber to indicate the sensor detects the object. If the sensor does not detect the object, the multicolor LED is red while the SETUP push-button is depressed, and when the SETUP push-button is released, the multicolor LED flashes red 2 seconds. After flashing red for 2 seconds, the sensor requests that span limit again by flashing green for the first span limit or flashing amber for the second span limit.

Once set, span limits are saved in nonvolatile memory and thus are retained when power is removed from the sensor.

Output State for Loss of Echo Selections

As shown in the Model Reference Guide, four selections are available to address loss of echo conditions for specific applications.

Selection “0” or “1” - Without Signal Hold on Loss of Echo

On power-up or when no echoes are detected for one second, for the 1 and 2 meter sensing span and 4 seconds for the 8 meter sensing span, the analog output will go to a minimum value for selection 0 or a maximum value for selection 1.

Selection “2” or “3” - With Signal Hold on Loss of Echo

If no echoes are received after power-up, the analog output value is a minimum when using selection 2 or a maximum when using selection 3. In addition, if echoes are not detected, the analog output value holds until echoes are once again received within the sensor's range.

Multicolor LED Operation

Red - object sensed closer than the near span limit.

Green - object sensed at or between the near and far span limits.

Amber - object sensed beyond the far span limit.

Off - no object sensed within the full sensing range.

Amber LED Operation

The amber LED intensity varies directly with the magnitude of the analog output. The amber LED is off when the output is at a minimum and full brightness when the output is at a maximum.

Electrical Wiring

The sensor wires must be run in conduit free of any AC power or control wires.

Dimensions

Cable Style

(ULTEM® plastic and stainless steel)
SM906A-1, SM906A-4, SM906A-7STS

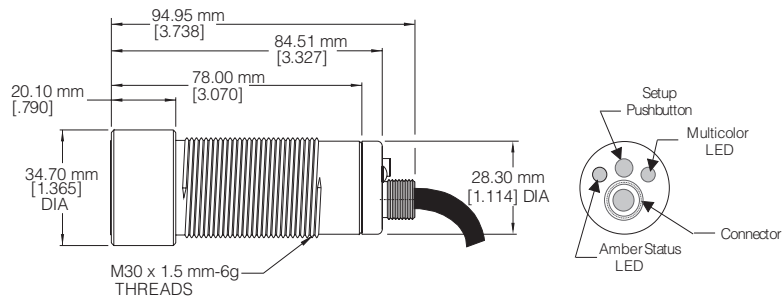

Connector Style

(ULTEM® plastic and Stainless Steel)
SM956A-1, SM956A-4, SM956A-7STS

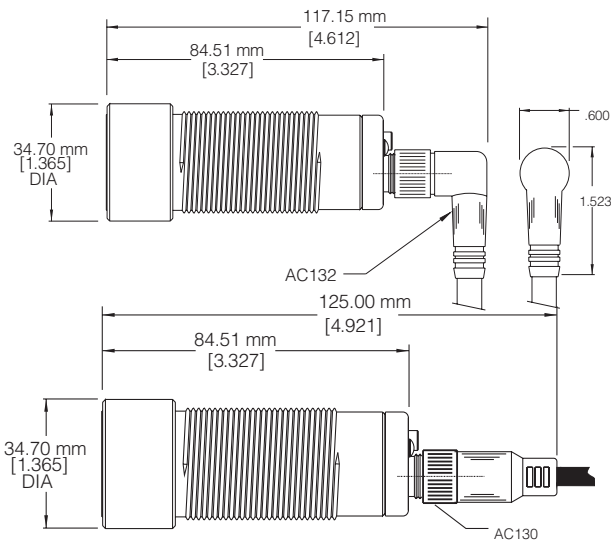
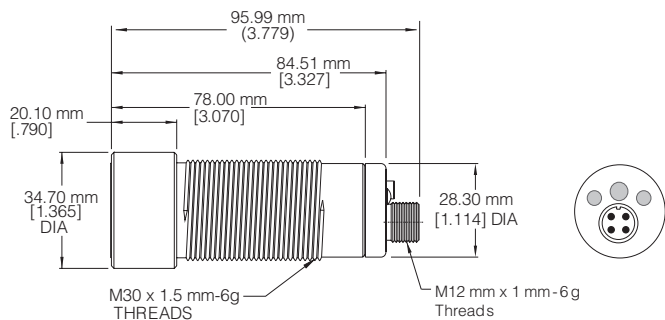

Cable Model Wire Assignments

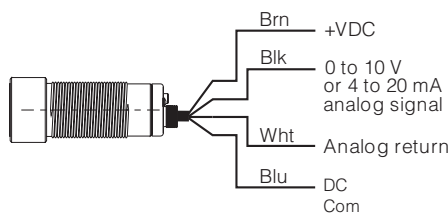

Connector Model Pin Assignments

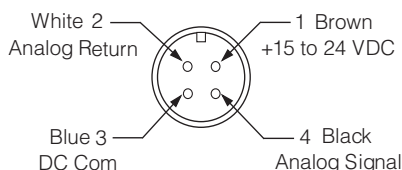

Cable Style

(ULTEM® plastic)
SM906A-8 long-range

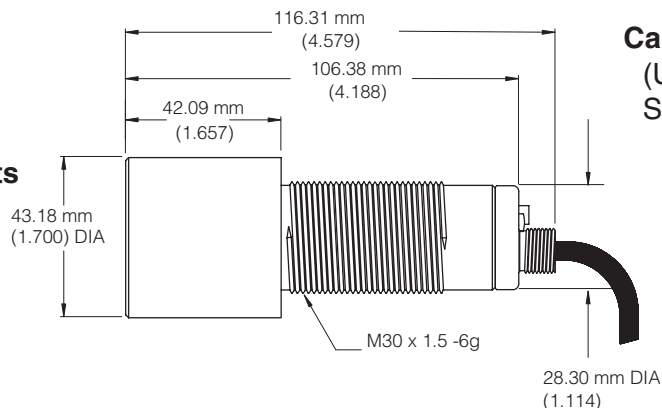

Connector Style
(ULTEM® plastic)
SM956A-8 long-range

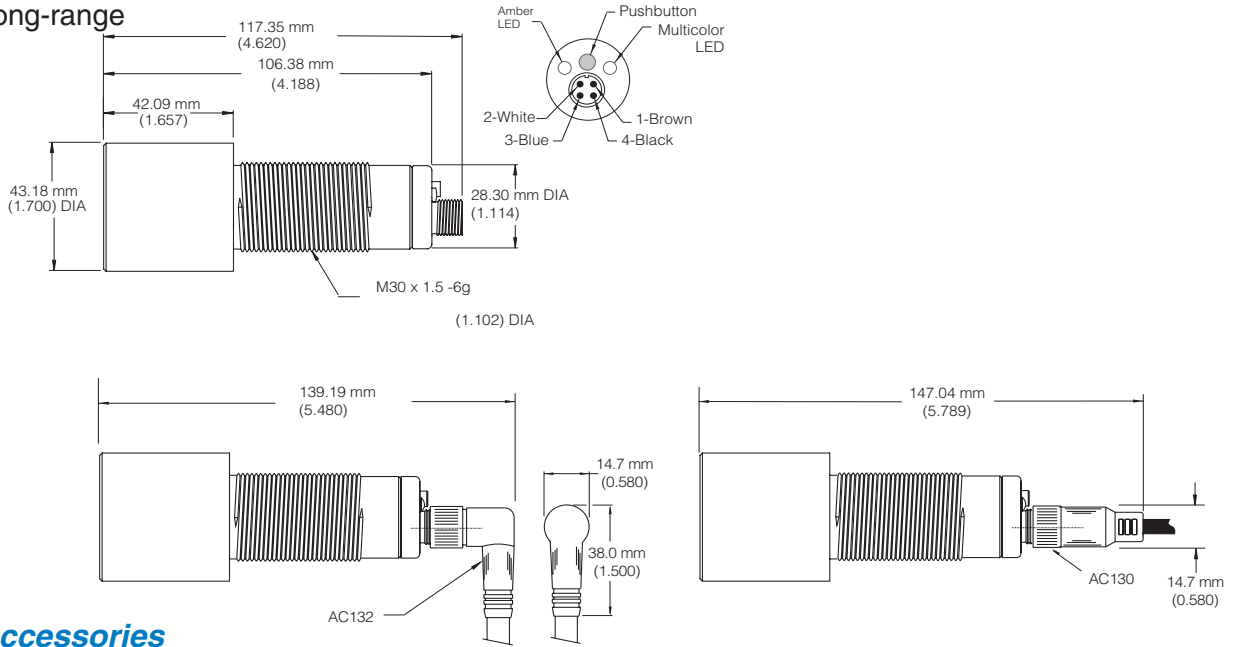

Mounting Accessories

AC130, Straight, M12 micro, 4-conductor, connector/
cable assembly, 5 m (16'), for 30 mm, barrel-style sensors

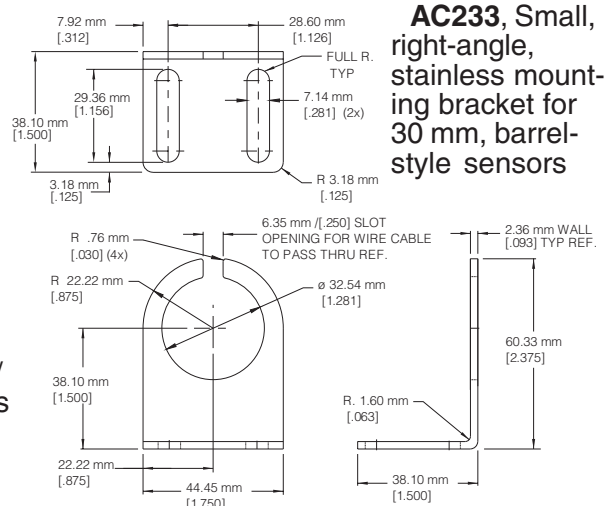
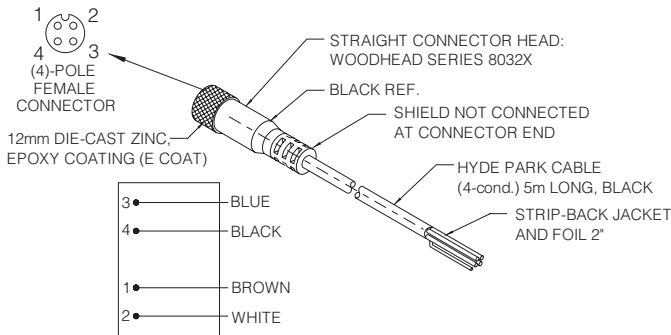

AC233, Small,
right-angle,
stainless mounting
bracket for
30 mm, barrel-
style sensors

AC132, Right-angle, M12 micro, 4-conductor, connector/
cable assembly, 5 m (16'), for 30 mm, barrel-style sensors

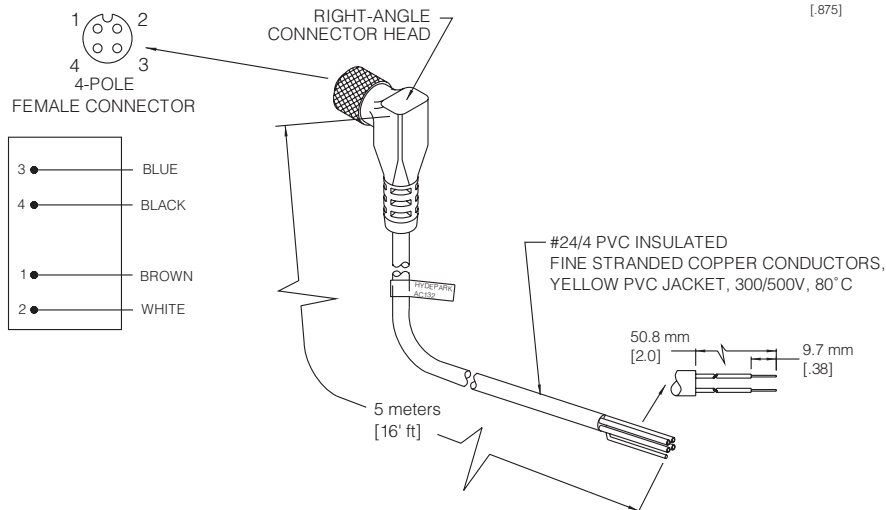

General Specifications

Sensing [TA = 20° C (68° F)]

1 and 2 meter ranges

Model Sensing Ranges:

- 51 mm to 1 m (2.0" to 39")
- 120 mm to 1 m (4.7 to 39")**
- 120 mm to 2 m (4.7 to 79")

Sonic Frequency: 200 kHz

Minimum Object-size Detection:

- 1.59 mm (0.0625") diameter rod up to 635 mm (26") distance from sensor

Maximum Angular Deviation:

- ± 10° on 305 mm x 305 mm (12" x 12") flat target at a distance of 305 mm (12")

Sonic Cone Profile: See Beam Plots, Page 4-109

Limit Adjustment Resolution: 0.08 mm (0.003")

Repeatability: ± 0.8716 mm (0.03431") max.

- Temperature Compensated

Power Requirements

Supply Voltage

15 to 24 VDC @ 80 mA, excluding output load

Current Consumption: 80 mA max., excluding load

Peak Inrush Current: 0.75 Amp.

Power Consumption: 1.2 W max., excluding load

Outputs

Output Range: 0 to 10 VDC or 4 to 20 mA, depending on model selected

Output Configuration:

- Inverse (0 to 10 VDC or 4 to 20 mA)
- Direct (10 to 0 VDC or 20 to 4 mA)

Voltage Output Slope: 33 mV/mm (0.833 V/inch) using a 305 mm (12") span

Minimum Load Resistance: 1 K Ohms

- (5 K Ohms recommended for best accuracy)

Current Output Slope: 52 µA/mm (1.33 mA/inch) using a 305 mm (12") span

Maximum Load Resistance: 500 Ohms

- (250 Ohms recommended for best accuracy)

Analog Output Electrical Specifications

(Test conditions: 24 VDC, TA = 20° C, large flat target, still air, @ minimum span size of 304.8 mm or 12")

	current output ¹	voltage output ²
Output Range	4-20 mA	0-10 V
Load Resistance (Ohms)	10 to 500	1 K to ∞
Resolution ³	4.88 µA	2.44 mVDC
Accuracy (% of span) ⁴	± 0.50	± 0.40
Linearity (% of span)	± 0.10	± 0.10
Temperature Dependence (% of span, °C)	± 0.006	± 0.004

¹tested with 250 Ohm load

²tested with 1000 Ohm load; a low value is recommended to minimize noise pickup

³resolution = span/4096; Maximum: 0.23 mm (0.009") for 1 meter model, max. span 0.459 mm (0.018") for 2 meter model, max. span

⁴best accuracy may be limited to 0.794 mm (0.03125") due to wave-skip phenomena

Response Times - Minimum, standard

15 ms on/off, 25 ms on/off (1 m range models)

20 ms on/off, 35 ms on/off (2 m range models)

Other response times are available.

Indicators

Multicolored (Amber, Red, Green) LED:

Indicates object position relative to the span limits

Red LED: Intensity increases as output signal increases.

Connection Options

Cable Style: 24 AWG, foil shield, lead-free PVC jacketed, 4-conductor, 3 meters (10') long, standard

Connector Style: 12 mm, 4-pole, male

Protectors

Power Supply: current-limited over-voltage, ESD, reverse polarity

Outputs: current-limited over-voltage, ESD, over-current

NOTE: This sensor is NOT RATED EXPLOSION PROOF.

Environmental

Operating Temperature Range:

0° to 50°C (32° to 122°F) for silicone-faced models

-20° to 50°C (-4° to 122°F) for stainless steel-faced models

Storage Temperature Range:

-40° to 100°C (-40° to 212°F) for silicone-faced models

-50° to 80°C (-58° to 176°F) for stainless steel-faced models

Operating Humidity: 100%

Protection Ratings: NEMA 4X (indoor use only), IP67

Chemical Resistance: Unaffected by most acids, bases, and oils. Fluorosilicone and stainless steel-faced transducers available for severe, corrosive-type environments.

Construction

Dimensions:

Cable Model: 30 mm (1.181") dia. x 1.5 mm-6g threaded housing x 94.95 mm (3.738") mm long, including 34.70 mm (1.365") dia. x 20.10 mm (0.790") long sensing head

Connector Model: 30 mm (1.181") dia x 1.5mm-6g threaded housing x 95.99 mm (3.779") long; 117.15 mm (4.612") long, including AC 132 right-angle, M12 micro, connector/cable assembly; 125 mm (4.921") long, including AC130 straight, M12 micro, connector/cable assembly; sensing head dimension same as cable model.

Housing: Epoxy encapsulated to resist shock and vibration

Case: ULTEM®* plastic or SS303 stainless steel
Transducer Face: Silicone rubber - gray
SS304 stainless steel, 0.051 mm (0.002") thick**

Sensor Cables: Lead-free, black PVC jacketed

8 meter, long range

Model Sensing Range:

203 mm to 8 m (8.0" to 26')

Sonic Frequency: 75 kHz

Minimum Object-size Detection:

50.8 mm (2.0") diameter rod up to 4572 mm (15') distance from the sensor

Maximum Angular Deviation:

± 10° on a large flat surface at a distance of 6.096 m (20')

± 5° on a large flat surface at a distance of 8 m (26') sonic cone profile: see beam plots, Page 4-109

Limit Adjustment Resolution: 0.254 mm (0.01")

Repeatability: ± 2.54 mm (0.10") max.

Temperature Compensated

Power Requirements

Supply Voltage

15 to 24 VDC ± 10%, excluding output load, regulated supply

Current Consumption: 80 mA max., excluding load

Peak Inrush Current: 0.75 Amp.

Power Consumption: 1.2 W max., excluding load

Outputs

Output Range: 0 to 10 VDC or 4 to 20 mA, depending on model selected

Output Configuration: Inverse (0 to 10 VDC or 4 to 20 mA) Direct (10 to 0 VDC or 20 to 4 mA)

Voltage Output Slope: 3.28 mV/mm (83.3 mV/inch) using a 3.048 mm (10') span

1.64 mV/mm (41.7 mV/inch) using a 6.096 mm (20') span

Minimum Load Resistance: 1 K Ohms

(5 K Ohms recommended for best accuracy)

Current Output Slope: 5.2 µA/mm (0.133 mA/inch) using a 3.48 mm (10') span

2.6 µA/mm (0.066 mA/inch) using a 6.096 mm (20') span

Maximum Load Resistance: 500 Ohms

Analog Output Electrical Specifications

(Test conditions: 24 VDC, TA = 20° C, large flat target, still air, @ minimum span size of 3.048 m or 10')

	current output ¹	voltage output ²
Output Range	4-20 mA	0-10 V
Load Resistance (Ohms)	10 to 500	1 K to ∞
Resolution ³	4.88 µA	2.44 mVDC
Accuracy (% of span) ⁴	± 0.50	± 0.40
Linearity (% of span)	± 0.15	± 0.15
Temperature Dependence (% of span/°C)	± 0.006	± 0.004

¹tested with 250 Ohm load

²tested with 1000 Ohm load; a low value is recommended to minimize noise pickup

³resolution = span/4096; Maximum: 1.90 mm (0.071") for 8 meter, long-range model, max. span

⁴best accuracy may be limited to 2.117 mm (0.083") due to wave-skip phenomena

**Available only in the stainless steel-faced, 1 m-span models

Response Times - Minimum, Standard

150 ms on/off, 250 ms on/off
Other response times are available.

Indicators

Multicolored (Amber, Red, Green) LED:
Indicates object position relative to the span limits.
Red LED:
Intensity increases as output signal increases.

Connection Options

Cable Style Models:
24 AWG, foil shield, lead-free PVC jacketed,
4-conductor, 3 meters (10') long, standard
Connector Style Models:
4-conductor, straight and right-angle "micro" style

Protection

Power Supply: current-limited over-voltage, ESD,
reverse polarity
Outputs: current-limited over-voltage, ESD,
over-current
NOTE: This sensor is NOT RATED EXPLOSION
PROOF.

Environmental

Operating Temperature Range:
-20° to 60° C (-4° to 140° F)
Storage Temperature Range:
-40° to 100° C (-40° to 212° F)
Operating Humidity: 100%
Protection Ratings: NEMA 4X (indoor use only), IP67
Chemical Resistance: Unaffected by most acids,
bases, and oils.

Construction

Dimensions:
Cable Model: 30 mm (1.181") dia. x 1.5 mm-6g
threaded housing x 94.95 mm (3.738") mm
long, including 34.70 mm (1.365") dia. x
20.10 mm (0.790") long sensing head
Connector Model: 30 mm (1.181") dia x 1.5 mm-6g
threaded housing x 95.99 mm (3.779")
long; 117.15 mm (4.612") long, including
AC132 right-angle, connector/ cable
assembly; 125.00 mm (4.921") long,
including AC130 straight, connector/cable
assembly; sensing head dimension same
as cable model.
Housing: Epoxy encapsulated to resist shock
and vibration
Case: ULTEM® plastic (FDA Approved)
Transducer Face: Epoxy - white
Sensor Cables: Lead-free, black PVC jacketed

Agency Approvals

CE Mark: CE conformity is declared to:
EN63126: 1997 (annex A, industrial) including
amendment A1:1998. EN55011 group 1 Class A.
Declaration of Conformity available upon request.

*ULTEM® is a registered trademark of The General
Electric Co.

Accessories

- Model AC130**, Straight, M12 micro, 4-conductor,
connector/cable assembly, 5 m (16')
- Model AC132**, Right-angle, M12 micro, 4-conductor,
connector/cable assembly, 5 m (16')
- Model AC233**, Small, right-angle, stainless, mounting
bracket
- Model AC250-n**, Tank sensor mounting reducer,
available with four different outside diameters;
used with all SUPERPROX® SM900 family sensors.
n = 1 (1 1/4" NPT); 2 (2" NPT); 3 (3" NPT); 4 (4"
NPT)
- Model AC251-n**, Tank sensor mounting flange,
available with three different pipe thread diameters,
furnished with matching AC250 Tank sensor
mounting reducer; used with all SUPERPROX®
SM900 family sensors. n = 2 (2" NPT); 3 (3" NPT);
4 (4" NPT)
- Model AC441A**, Handheld configurator

See Page 7-1 for accessory photos.

Selection Chart

SM906 Series

Level/Distance with Analog Output

Model No.	12/24 VDC Power Version		Connection Style		Analog Span				Output Signal				Output state on loss of Echo Power Up				Transducer		Materials		Housing		Response Time	No Foreground or Background Suppr.	Functionality	
	Cable	Connector	51 mm - 1 m. 2' - 39"	120 mm - 2 m 4.7' - 79"	120 mm - 1 m 4.7' - 39"	203 mm - 8 m 8' - 26"	Inv. 0-10V	Dir. 0-10V	Inv. 4-20 mA	Dir. 4-20 mA	Minimum	Maximum	Hold on loss of echo min. on power up	Hold on loss of echo max. on power up	Silicone	Stainless	Fluorosilicone	Epoxy	30 mm ULTEM®	30 mm stainless	Foreground Suppr. (Object Mode)	Foreground Suppr. (Background Mode)			Fg & Bg Suppr. (Background Mode)	
SM906A-100000	■	■	■				■								■						25 ms	■				
SM906A-102000	■	■	■				■					■			■						25 ms	■				
SM906A-103100S	■	■	■				■							■	■					■	15 ms	■				
SM906A-111000	■	■	■					■				■			■						25 ms	■				
SM906A-120000	■	■	■									■			■						25 ms	■				
SM906A-122000	■	■	■									■			■						25 ms	■				
SM906A-122203	■	■	■									■			■						100 ms			■		
SM906A-122600S	■	■	■									■			■					■	2.50 s	■				
SM906A-132000	■	■	■									■			■						25 ms	■				
SM906A-133000FS	■	■	■									■			■		■				25 ms	■				
SM906A-400000	■	■		■				■				■			■						35 ms	■				
SM906A-400000S	■	■		■				■				■			■					■	35 ms	■				
SM906A-410000	■	■		■					■						■						35 ms	■				
SM906A-411000	■	■		■					■						■						35 ms	■				
SM906A-430000	■	■		■						■					■						35 ms	■				
SM906A-431000	■	■		■						■					■						35 ms	■				
SM906A-432000	■	■		■						■					■						35 ms	■				
SM906A-721000STS	■	■			■							■				■				■	25 ms	■				
SM906A-800000	■	■				■						■			■						250 ms	■				
SM906A-832000	■	■				■						■			■						250 ms	■				
SM956A-100000	■	■	■	■				■				■			■						25 ms	■				
SM956A-102000	■	■	■	■				■				■			■						25 ms	■				
SM956A-110000	■	■	■	■					■						■						25 ms	■				
SM956A-110000S	■	■	■	■					■						■				■		25 ms	■				
SM956A-111000	■	■	■	■					■						■						25 ms	■				
SM956A-120000	■	■	■	■						■					■						25 ms	■				
SM956A-122000	■	■	■	■						■					■						25 ms	■				
SM956A-123600S	■	■	■	■						■					■					■	2.50 s	■				
SM956A-130000	■	■	■	■							■				■						25 ms	■				
SM956A-130003S	■	■	■	■							■				■					■	25 ms	■		■		
SM956A-131000	■	■	■	■							■				■						25 ms	■				
SM956A-131101S	■	■	■	■							■				■					■	15 ms		■			
SM956A-132000	■	■	■	■							■				■						25 ms	■				
SM956A-132400S	■	■	■	■							■				■					■	500 ms	■				
SM956A-133000	■	■	■	■							■				■						25 ms	■				
SM956A-133003	■	■	■	■							■				■						25 ms			■		
SM956A-133600	■	■	■	■							■				■						2.50 s	■				
SM956A-400000	■	■		■				■							■						35 ms	■				
SM956A-402000	■	■		■				■							■						35 ms	■				
SM956A-410000	■	■		■					■						■						35 ms	■				
SM956A-412000	■	■		■					■						■						35 ms	■				
SM956A-420000	■	■		■						■					■						35 ms	■				
SM956A-420200	■	■		■						■					■						100 ms	■				
SM956A-430000	■	■		■							■				■						35 ms	■				
SM956A-432000	■	■		■							■				■						35 ms	■				
SM956A-432303	■	■		■							■				■						250 ms			■		
SM956A-733003STS	■	■			■						■					■				■	25 ms			■		
SM956A-800000	■	■				■	■				■						■	■			250 ms	■				
SM956A-820000	■	■				■					■						■	■			250 ms	■				

All possible sensor configurations are not listed here.