

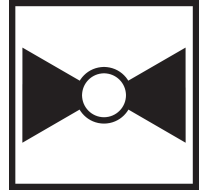

5-year warranty



Type overview

Type	DN	ANSI Class
F6100-300SHP	100	300

Technical data

Functional data	Fluid	chilled or hot water, up to 60% glycol, steam
Body Pressure Rating		ANSI Class 300
Close-off pressure Δ ps		285 kPa
Servicing		maintenance-free
Flow Pattern		2-way
Footnotes		Close-off pressures are variable and actuator dependent, consult Select Pro and/or Price Guide for specifics.
Leakage rate		0%
Controllable flow range		quarter turn, mechanically limited
Cv		451
Maximum Inlet Pressure (Steam)		50 psi
Fluid Temp Range (water)		-22...400°F [-30...204°C]
ANSI Class		300
Maximum Velocity		32 FPS
Lug threads		3/4-10 UNC
Valve Size		4" [100]
Materials	Seat	RPTFE
End fitting		ASME/ANSI class 300 flange
Bearing		glass backed PTFE
Disc		316 stainless steel
Gland Seal		TFE
Gear operator materials		Gears - hardened steel

Safety notes



- Cable for ZIP-RS232 US and ZIP-USB-MP US to Belimo gateways.
- Classic GM to GMB(X) retrofit bracket.
- Battery Back Up System for SY(7-10)-110
- Weather shield - galvaneal 13x8x6" (LxWxD).
- Cable for ZTH US to diagnostic/programming socket.
- Cable for ZTH US to actuators w/o diagnostics socket.
- 50% voltage divider kit (resistors with wires).

- PC Tool computer programming interface, serial port.
- 3/4" shaft adaptor for ZS-300(-5).
- Battery Back Up System for SY(8-12)-110P
- MFT95 resistor kit for 4 to 20 mA control applications.



WARNING: This product can expose you to lead which is known to the State of California to cause cancer and reproductive harm. For more information go to www.p65warnings.ca.gov

Product features

Product features Double Dead End Service: Utilises larger retainer-ring setscrews to allow the valve to be placed at the end of the line without a down-stream flange in either flow direction at full pressure. The High Performance Butterfly Valve features a double offset (or, double eccentric) shaft design to minimize seat abrasion and lower torque. This double offset design allows the disc to lift off and come away from the seat as it rotates open. The face-to-face dimensions are API 609 & MSS-SP-68 compliant and are designed to be installed between ASME/ANSI B16.5 flanges. Every valve has a metal identification tag attached to the valve body. Information includes the figure number, the size and pressure class, the materials of construction, and the operating pressures and temperatures.

Application These valves are designed to meet the needs of HVAC and commercial applications requiring bubble tight shut-off for liquids. Typical applications include chiller isolation, cooling tower isolation, change-over systems, large air handler coil control, bypass and process control applications. The large Cv values provide for an economical control valve solution for larger flow applications.

Flow/Mounting details

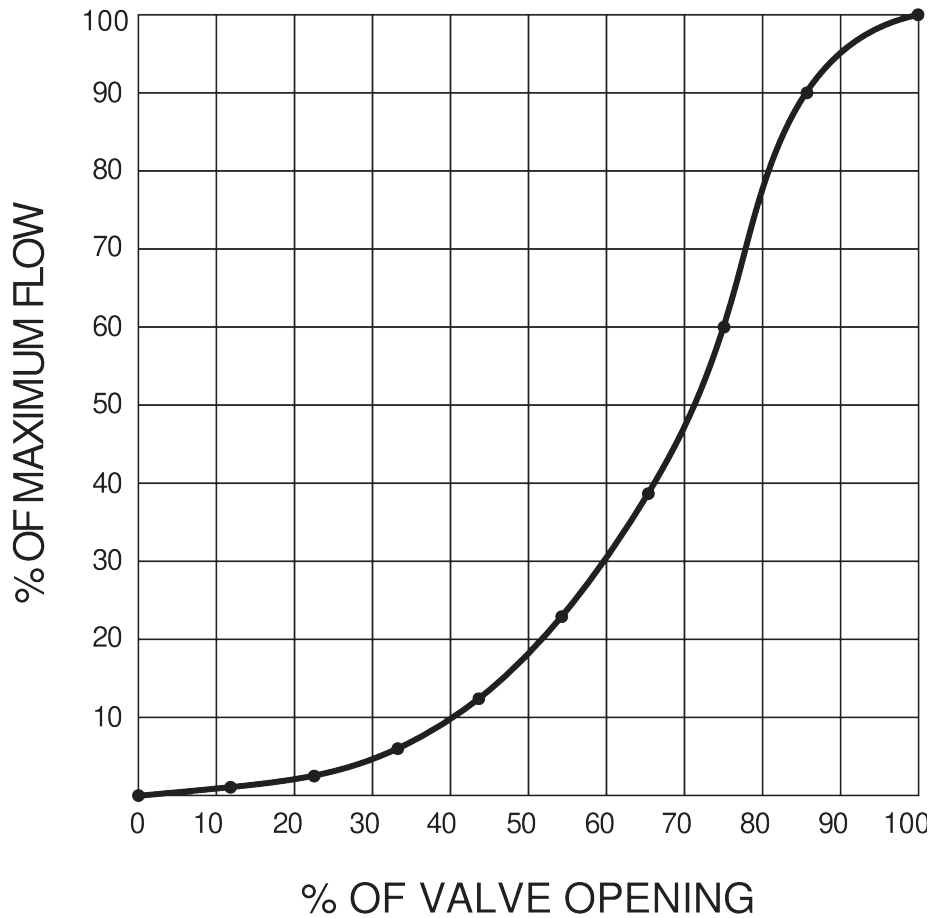

Dimensions

Dimensional drawings

2*GKB(X)

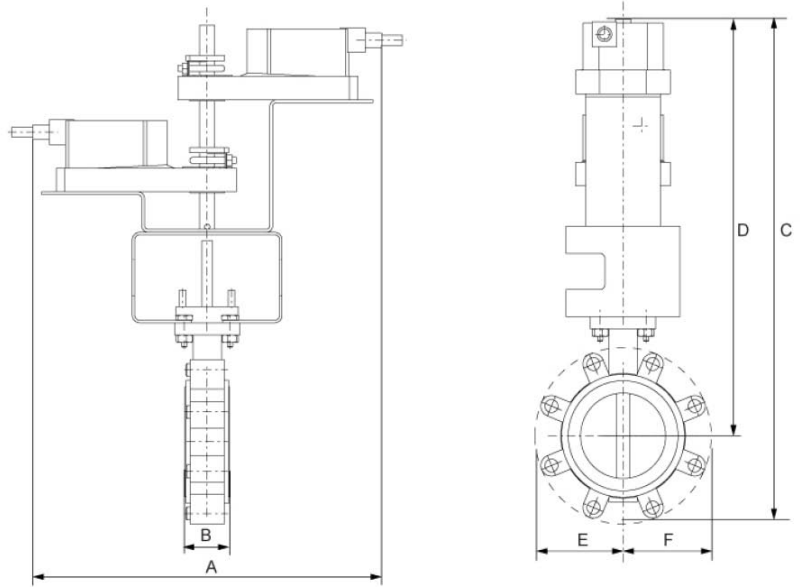

A	B	C	D	E	F
18.9" [480]	2.2" [56]	18.7" [476]	14.0" [355]	4.9" [124]	4.9" [125]

2*GMB(X)

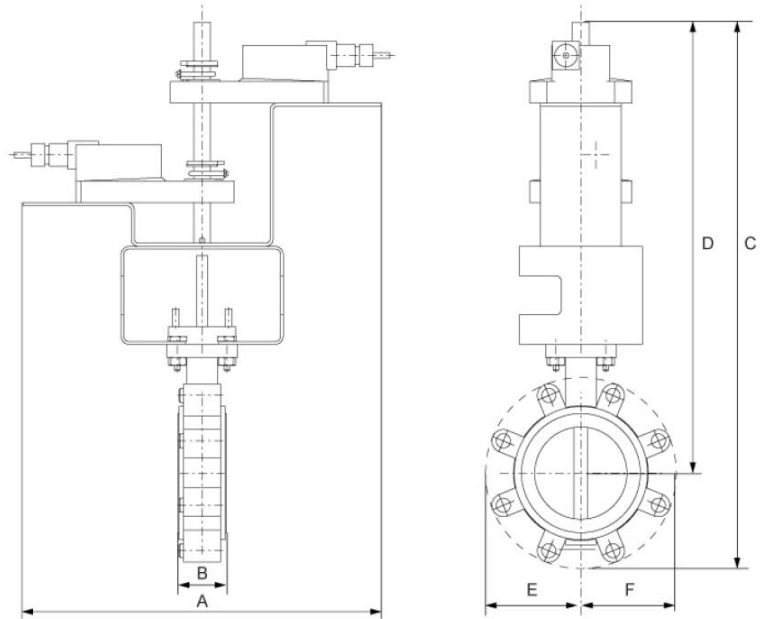

A	B	C	D	E	F
15.3" [388]	2.2" [56]	16.8" [426]	13.0" [331]	3.9" [100]	3.9" [100]

GKB(X)

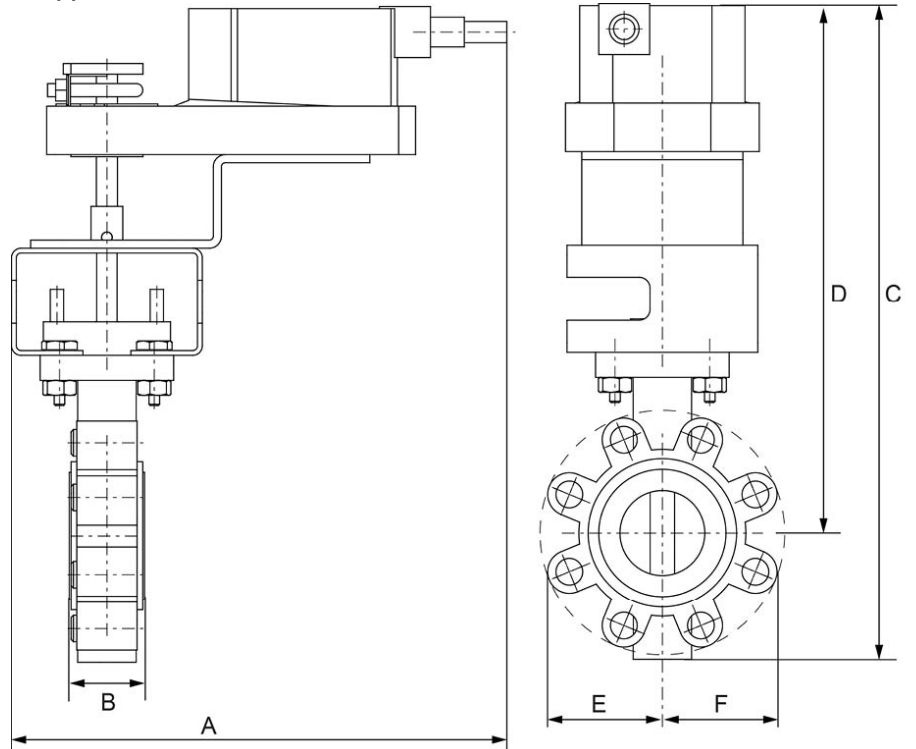

A	B	C	D	E	F
10.9" [277]	2.2" [56]	18.7" [476]	14.0" [355]	4.9" [124]	4.9" [125]

GMB(X)

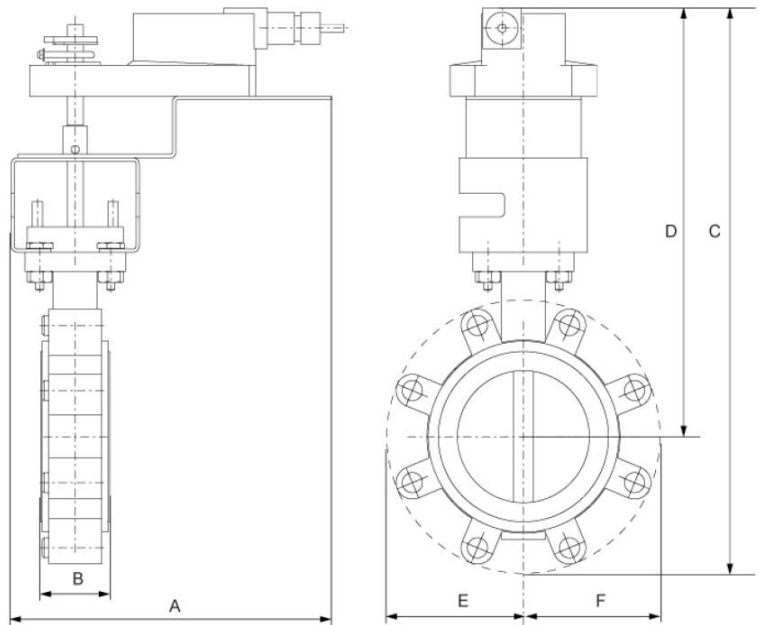

A	B	C	D	E	F
9.1" [231]	2.2" [56]	17.2" [438]	13.5" [342]	3.9" [100]	3.9" [100]

GMB(X) N4

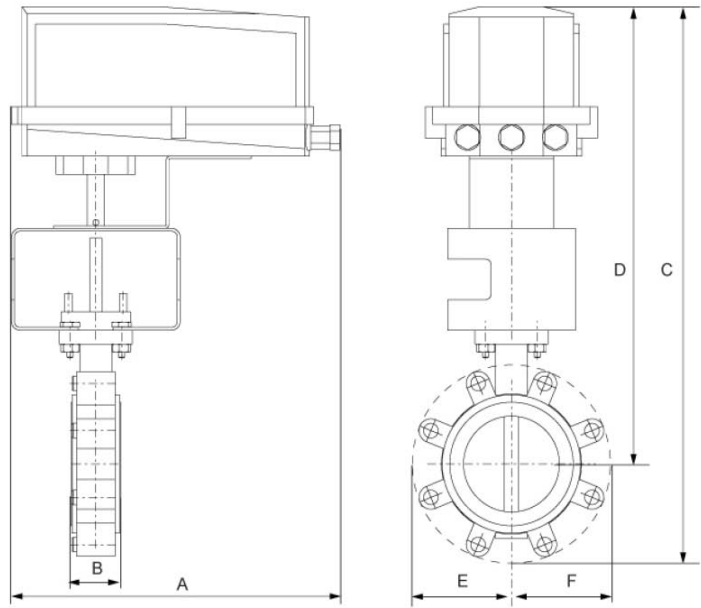

A	B	C	D	E	F
14.1" [358]	2.2" [56]	20.6" [523]	15.3" [388]	5.4" [137]	5.4" [137]