

M Series Basic Valves

Solenoid (On-Off) Control Valve (4" and Smaller)

Full Port Ductile Iron Single Chamber Basic Valve

This Watts Automatic Control Valve (ACV) is a full port, single chamber basic valve that incorporates a one-piece disc and diaphragm assembly. This assembly is the only moving part within the valve allowing it to open, close, or modulate as commanded by the pilot control system.

Watts ACV Main Valves are Lead Free. The Watts ACV piloting system contains Lead Free* components, ensuring all of our configurations are Lead Free compliant.

Globe Pattern Single Chamber Basic Valve (M100)
Angle Pattern Single Chamber Basic Valve (M1100)

Basic Valve Body Options



Globe Flanged



Angle Flanged



Globe Grooved End



Angle Grooved End



Globe Threaded



Angle Threaded

Standard Materials

Body and Cover: Ductile Iron ASTM A536

Coating: NSF Listed Fusion Bonded Epoxy Lined and Coated

Trim: 316 Stainless Steel

Elastomers: Buna-N (standard)
EPDM (optional)
Viton® (optional)



Nut, Spring and Stem: Stainless Steel

Anti-Scale (Optional): Xylan Coated Stem and Seat

Viton® is a registered trademark of DuPont Dow Elastomers.

Operating Pressure

Threaded = 400psi (27.6 bar)

150# Flanged = 250psi (17.2 bar)

300# Flanged = 400psi (27.6 bar)

Grooved End = 400psi (27.6 bar)

Operating Temperature

Buna-N: 160°F (71°C) Maximum

EPDM: 300°F (140°C) Maximum

Viton®: 250°F (121°C) Maximum

Epoxy Coating**: 225°F (107°C) Maximum

** Valves can be provided without internal epoxy coating consult factory

ACV Schematic - Series LFM113-12

Flow Data

Valve Size - Inches		1/4	1/2	2	2 1/2	3	4	6	8	10	12	14	16
Suggested	Maximum Continuous Flow Rate Gpm (Water)	95	130	210	300	485	800	1850	3100	5000	7000	8500	11100
	Maximum Intermittent Flow Rate Gpm (Water)	119	161	265	390	590	1000	2300	4000	6250	8900	10800	14100
	Minimum Flow Rate Gpm (Water)	3	5	6	9	15	16	17	25	55	70	190	400
Cv	Cv Factor GPM (Globe)	26	26	48	75	112	188	387	764	1215	1734	2234	3131
	Cv Factor GPM (Angle)	26	27	57	91	125	207	571	889	1530	1945		

- Maximum continuous flow based on velocity of 20 ft. per second.
- Maximum intermittent flow based on velocity of 25 ft. per second.
- Minimum flow rates based on a 20-40 psi pressure drop.
- The Cv Factor of a valve is the flow rate in US GPM at 60°F that will cause a 1psi drop in pressure.
- Cv factor can be used in the following equations to determine Flow (Q) and Pressure Drop (ΔP):

$$Q (\text{Flow}) = C_v \sqrt{\Delta P} \quad \Delta P (\text{Pressure Drop}) = (Q/C_v)^2$$

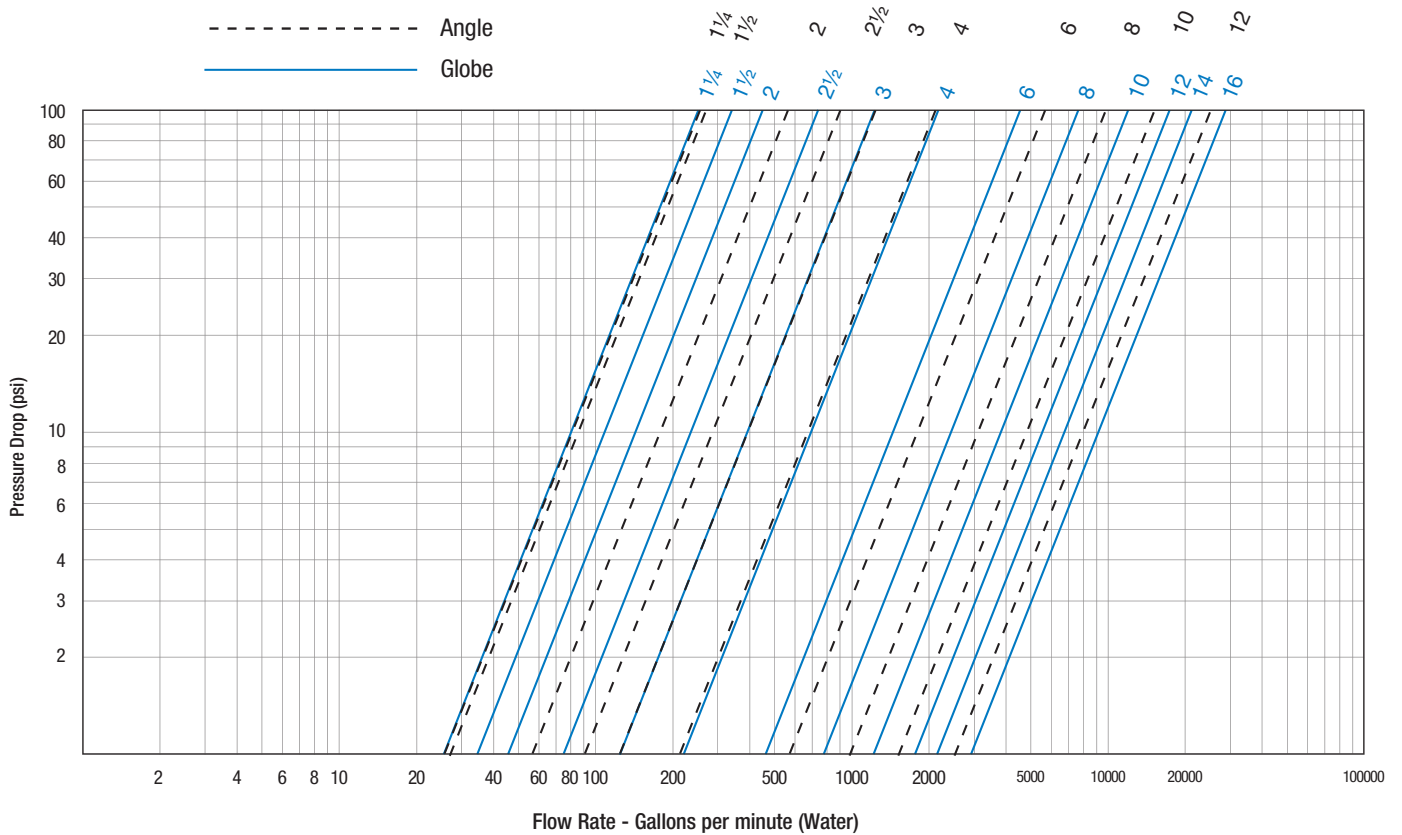

Valve Cover Chamber Capacity

Valve Size - Inches	1/4	1/2	2	2 1/2	3	4	6	8	10	12	14	16
ft.oz.	4	4	4	10	16	22	70					
U.S. Gal								1 1/4	2 1/2	4	6 1/2	9 1/2

Valve Travel

Valve Size - Inches	1/4	1/2	2	2 1/2	3	4	6	8	10	12	14	16
Travel - Inches	3/8	3/8	1/2	5/8	3/4	1	1 1/2	2	2 1/2	3	3 1/2	4

ACV Schematic - Series LFM113-12

Basic Valve

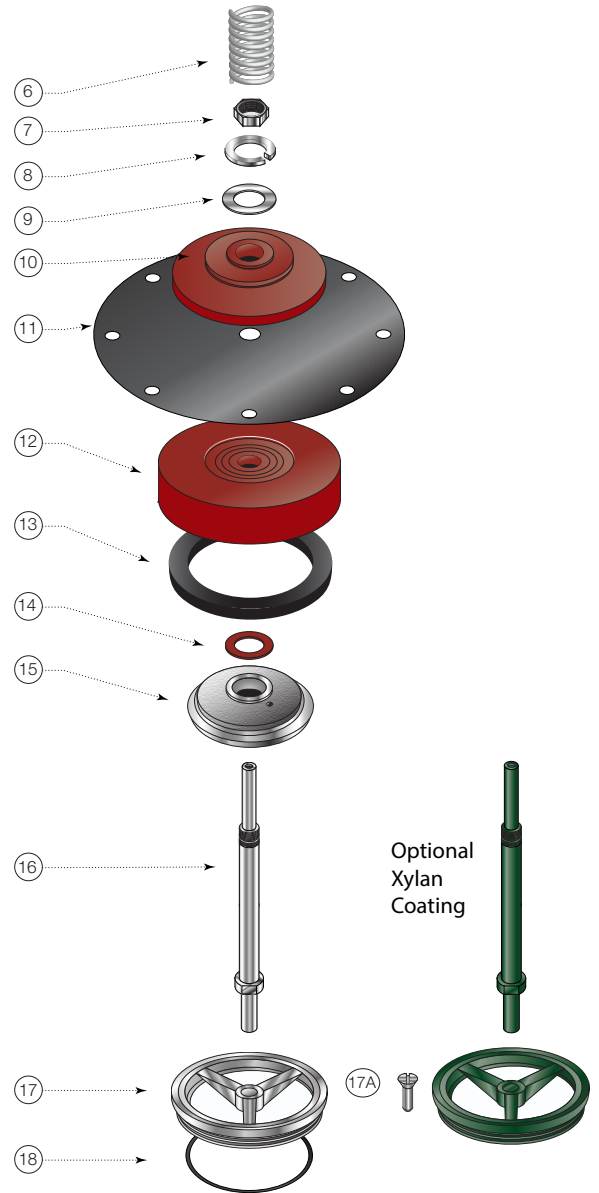
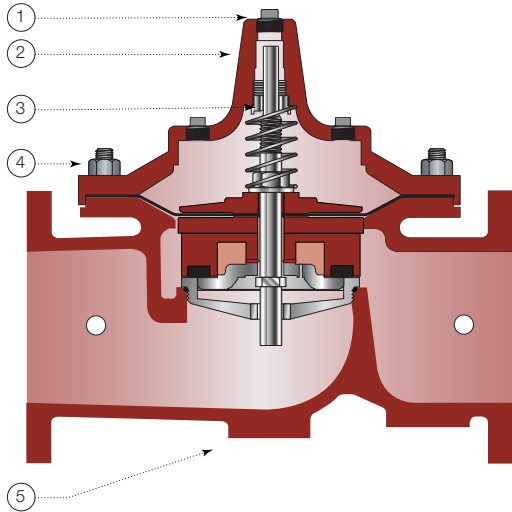

Item	Description	Material
1	Pipe Plug	Lead Free Brass
2	Cover	ASTM A536 65-45-12 Epoxy Coated Ductile Iron
3	Cover Bearing	ASTM A276 304 Stainless Steel
4	Stud with Cover Nut and Washer	ASTM A570 Gr.33 Zinc Plated Steel
5	Body	ASTM A536 65-45-12 Epoxy Coated Ductile Iron
6	Spring	ASTM A276 302 Stainless Steel
7	Stem Nut	ASTM A276 304 Stainless Steel
8	Lock Washer	ASTM A276 304 Stainless Steel
9	Stem Washer	ASTM A276 304 Stainless Steel
10	Diaphragm Washer	ASTM A536 65-45-12 Epoxy Coated Ductile Iron
11	Diaphragm*	Buna-N (Nitrile)
12	Disc Retainer	ASTM A536 65-45-12 Epoxy Coated Ductile Iron
13	Seat Disc*	Buna-N (Nitrile)
14	Spacer Washer* x5	NY300 Fiber*
15	Disc Guide	ASTM A743 CF8M (316) Stainless Steel
16	Shaft	ASTM A276 304 Stainless Steel
17	Seat Ring**	ASTM A743 CF8M (316) Stainless Steel
17A	Seat Screw** (8" and Larger)	ASTM A276 304 Stainless Steel
18	Seat Gasket*	Buna-N (Nitrile)

* Contained in Main Valve Repair Kit
 **Note: 6 inch and Smaller Valves, Seat Ring is threaded

NOTICE

Installation: If unit is installed in any orientation other than horizontal (cover up) OR extreme space constraints exist, consult customer service prior to or at the time of order.

ACV Schematic - Series LFM113-12

Dimensions

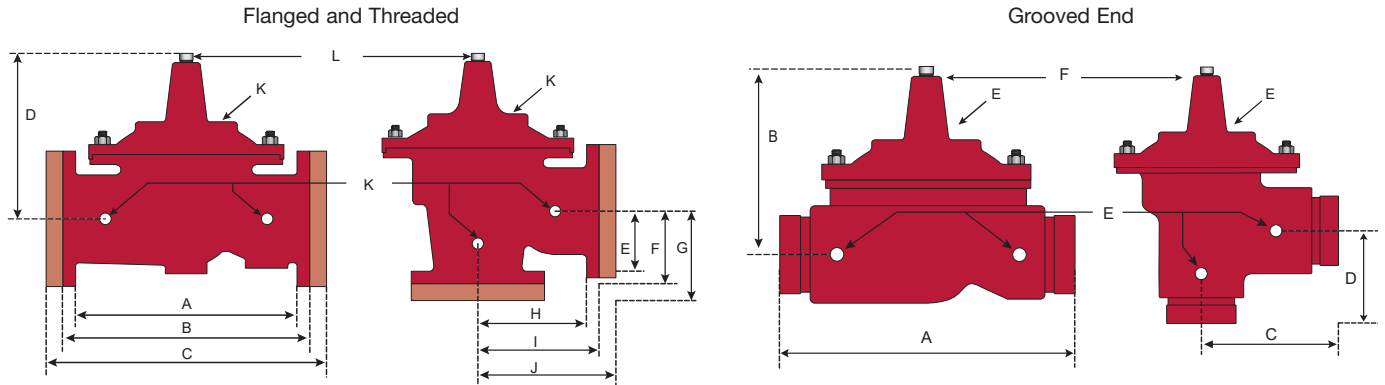

Flanged and Threaded Dimensions

Valve Size	Globe Thread		Globe 150#		Globe 300#		Cover To Center		Angle Thread		Angle 150#		Angle 300#		Angle Thread		Angle 150#		Angle 300#		Port Size NPT	Port Size NPT	Shipping Weights*	
	A	B	C	D	E	F	G	H	I	J	K	L												
in.	in.	mm	in.	mm	in.	mm	in.	mm	in.	mm	in.	mm	in.	mm	in.	mm	in.	mm	in.	mm	in.	in.	lbs.	kgs.
1¼	7¼	184					5½	140													¾	¼	20	9
1½	7¼	184	8½	216			5½	140	¾	83					1⅞	48					¾	¼	25	11
2	9⅞	238	9⅞	238	10	254	6¾	171	4¾	120	4¾	121	5	127	3¼	83	3¼	83	3½	89	¾	½	40	18
2½	11	279	11	279	11⅝	295	7½	191	5½	140	5½	140	5⅞	149	4	102	4	102	4⅞	110	½	½	65	29
3	12½	318	12	305	13¼	337	8¼	210	6¼	159	6	152	6⅝	162	4½	114	4	102	4⅞	111	½	½	95	43
4			15	381	15⅝	397	10⅞	270			7½	191	7⅞	200			5	127	5⅞	135	¾	¾	190	86
6			20	508	21	533	13	330			10	254	10½	267			6	152	6½	165	¾	¾	320	145
8			25⅜	645	26⅜	670	16	406			12¾	324	13¼	337			8	203	8½	216	1	1	650	295
10			29¾	756	31⅞	791	17	430			14⅞	378	15⅞	395			8⅞	219	9⅞	237	1	1	940	426
12			34	864	35½	902	20⅞	530			17	432	17¾	451			13¾	349	14½	368	1	1¼	1500	680
14			39	991	40½	1029	24¼	616													1	1½	1675	760
16			41⅜	1051	43½	1105	25¼	640													1	2	3100	1406

Grooved End Dimensions

Valve Size	Globe Grooved		Cover To Center		Angle Grooved		Angle Grooved		Port Size (npt)	Port Size (npt)	Shipping Weights*	
	A	B	C	D	E	F						
in.	in.	mm	in.	mm	in.	mm	in.	mm	in.	in.	lbs.	kgs.
1¼	8½	216	5½	140	4¼	108	¾	83	¾	¼	25	11
1½	8½	216	5½	140	4¼	108	¾	83	¾	¼	25	11
2	9	229	6½	165	4¾	121	¾	83	¾	½	40	18
2½	11	279	7½	191	5½	140	4	102	½	½	65	29
3	12½	318	8¼	210	6	152	4¼	108	½	½	95	43
4	15	381	10⅞	270	7½	191	5	127	¾	¾	190	86
6	20	508	13⅜	340					¾	¾	320	145
8	25⅜	645	16	406					1	1	650	295

Model S3W

3-Way Solenoid

Size: 1/8" – 1/2" NPT

Model S3W are pilot system 3-way solenoids. The solenoids can control valves independently or in combination with other control circuit pilots or accessories. Product is available with a wide range of options including: voltage (24VDC, 24VAC or 120VAC), operation (energize to open or closed) and a range of enclosures (general service to watertight to explosion proof).

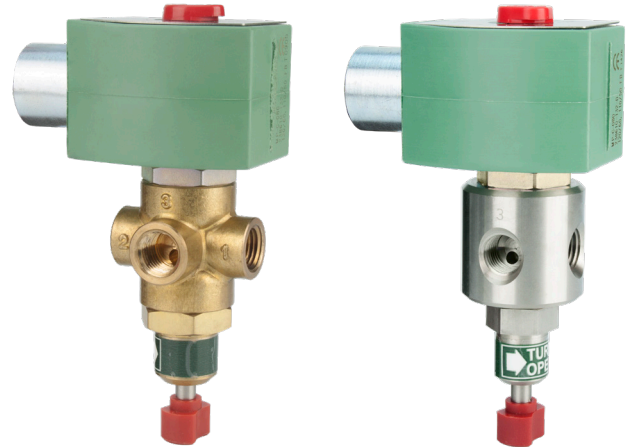

Model S3W
Brass

Model S3W
Stainless Steel

Manual Operator

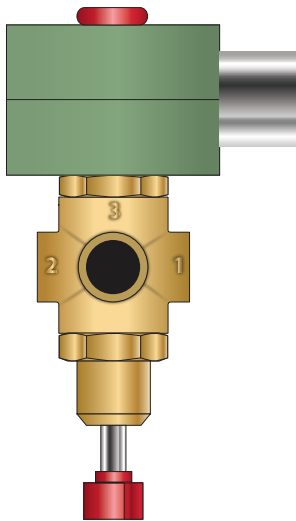

Normal Operating Condition

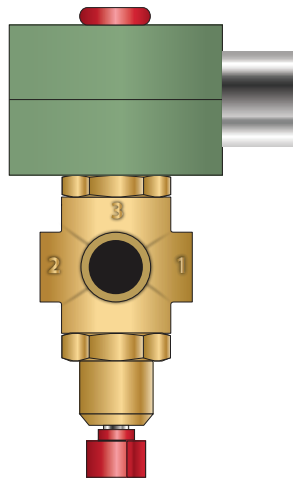

Manual Override

Specifications

- Body Material:** Brass (standard)**
Stainless Steel (optional)
- Elastomers:** Nitrile (standard)
EPDM (optional)
Viton® (optional)
- Voltage:** 24VDC, 24VAC or 120VAC
- Enclosure:** General Purpose – NEMA 4 (standard)
Explosion Proof – NEMA 6, 6P, 7, 9 (optional)
- Action:** Normally Open or Normally Closed**

**Solenoid Action only. Main valve action (energize-to-open or energize-to-close) is dependent on the particulars of the pilot system.

***Brass solenoids are not lead free and it is illegal to use them in potable services in the United States such as drinking water, handwashing, food preparation, and dishwashing. However, brass solenoids may be used as a replacement component in a lead free Watts ACV main valve, as the wetted surface of a lead free Watts ACV main valve including installed brass solenoids contains less than 0.25% of lead by weight.

Viton® is a registered trademark of DuPont Dow Elastomers.

*The wetted surface of this product contacted by consumable water contains less than 0.25% of lead by weight.

LEAD FREE*

Model BV

Ball Valve

Size: 1/4" – 1" NPT

Model BV Ball Valves are used in pilot lines to provide a positive shutoff in any override or maintenance situation for simple trouble shooting. This 2-piece, full port valve features: bottom loaded stems, PTFE seats and packing.

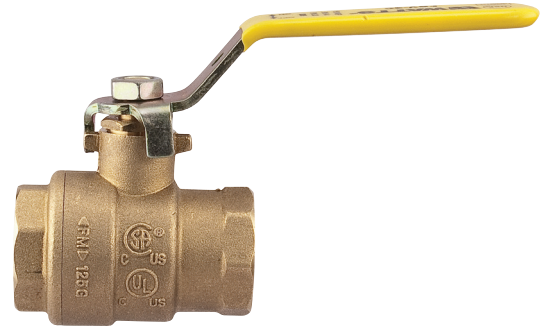

Model LFBV

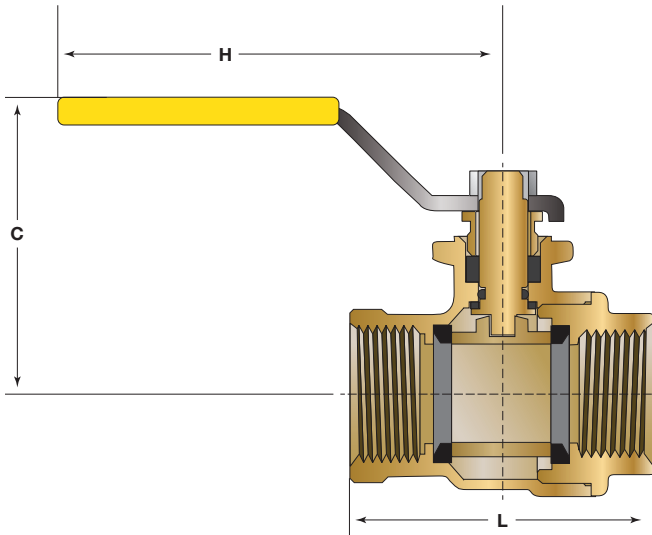

Specifications

Standard Material: Copper Silicon Alloy Body and Adaptor
Chrome Plated Ball

Optional Material: Stainless Steel Housing, Body and Adaptor
Stainless Steel Ball

Pressure Rating: 600psi (41 bar) Non Shock

Temp Rating: -40°F – 400°F

*The wetted surface of this product contacted by consumable water contains less than 0.25% of lead by weight.

Size	Dimensions						Weight	
	C		H		L		lbs.	kg.
in.	in.	mm	in.	mm	in.	mm		
1/4	1 13/16	46	3 7/16	87	1 3/4	45	0.4	0.2
3/8	1 13/16	46	3 7/16	87	1 3/4	45	0.4	0.2
1/2	1 13/16	46	3 7/16	87	1 5/16	50	0.4	0.2
3/4	2 1/4	57	4	101	2 5/16	59	0.8	0.3

LEAD FREE*

Model LF60

Flo-Clean Strainer

Size: 1/4" – 3/4" NPT

Model LF60 Flo-Clean Strainers are used to filter the fluid passing through the pilot circuit, and provide protection to pilot circuit speed controls and pilots. It is installed in the inlet body port of the Main Valve, exposing the strainer element to main line flow. The currents and flow across the screen create a self-scouring effect, cleaning the filter element.

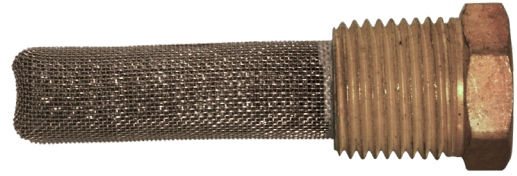

Model LF60

Valve inlet with Filter installed

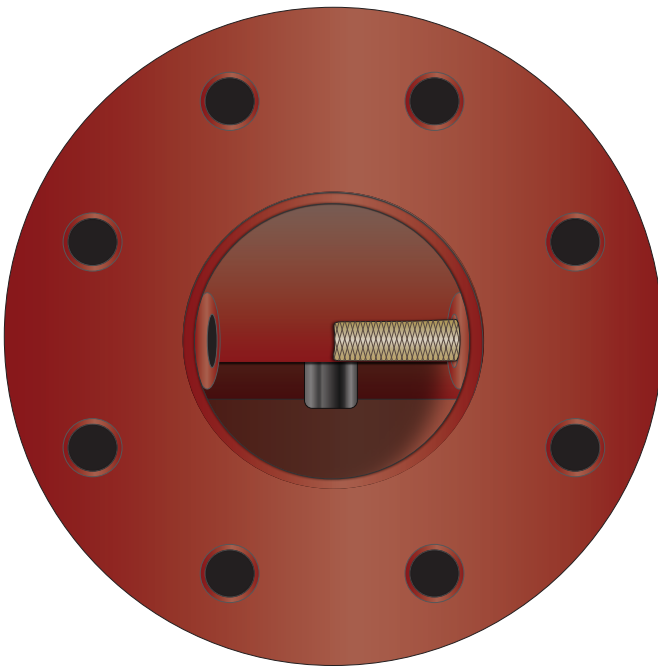

Specifications

- Body Material:** Lead Free Brass (standard)
Stainless Steel (optional)
- Pressure Rating:** 400psi (27.6 bar)
- Filter Element:** Monel
- Screen Mesh:** 40 Mesh (standard)

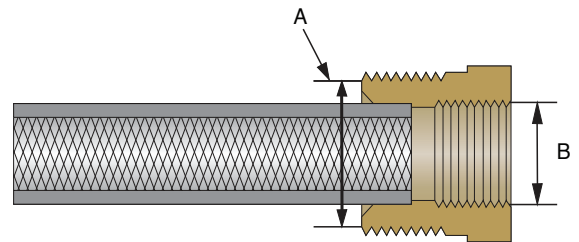

A	B
Male Pipe Thread	Female Pipe Thread
in.	in.
1/4	1/8
3/8	1/4
1/2	3/8

*The wetted surface of this product contacted by consumable water contains less than 0.25% of lead by weight.

LEAD FREE*

Model LF60-1

Y-Pattern Strainer

Size: 1/4" – 3/4" NPT

Model LF60-1 Y-Pattern Strainers are used to filter the fluid passing through the pilot circuit, and provide protection to pilot circuit speed controls and pilots. The filter element can be accessed for cleaning by removing the clean-out cap, or may be cleaned by installing an optional "blow-down" ball valve.



Model LF60-1

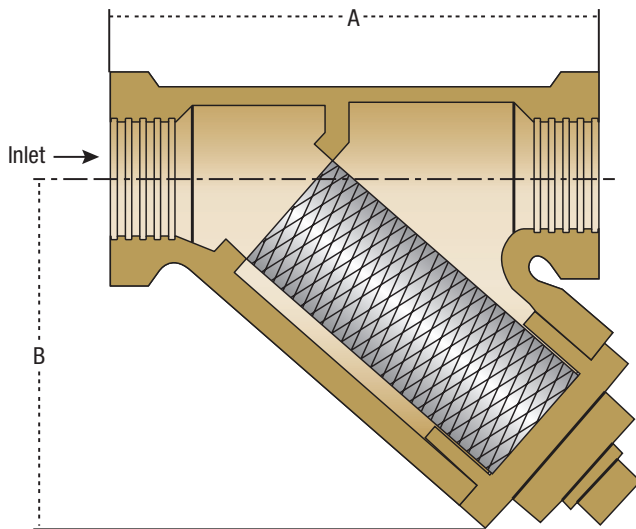

Specifications

- Body Material:** Lead Free Copper Silicon Alloy
CF8M (316) Stainless Steel (optional)
- Retainer Cap:** Lead Free Copper Silicon Alloy
- Cap Gasket:** EPDM
- Pressure Rating:** 400psi (27.6 bar)
- Filter Element:** 304 Stainless Steel
- Mesh Options:** 60 Mesh (standard)
100 Mesh (optional)

Dimensions

SIZE	DIMENSIONS				WEIGHT	
	A		B		lbs.	kgs.
in.	in	mm	in	mm		
1/4	2 1/16	68	1 1/16	43	1.7	0.77
3/8	2 1/16	68	1 1/16	43	1.7	0.77
1/2	3	76	2	51	1.7	0.77
3/4	3 5/16	84	2 5/16	59	1.7	0.77

*The wetted surface of this product contacted by consumable water contains less than 0.25% of lead by weight.

LEAD FREE*

Model LFFC

Flow Control

Size: Standard Flow - 1/2" MNPT x 3/8" FNPT
 High Flow - 1/2" MxF NPT

A Flow Control is an adjustable device used for tuning valve performance. It can be installed to either control the opening or closing the speed of the automatic control main valve. When the flow is in the direction of the needle the flow control is an adjustable restriction. In the free flow direction the seat moves out of the flow path to all unrestricted flow.

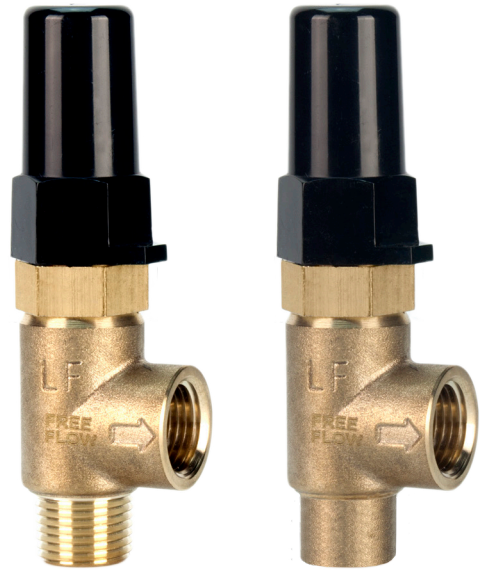

Large Flow Control

Standard Flow Control

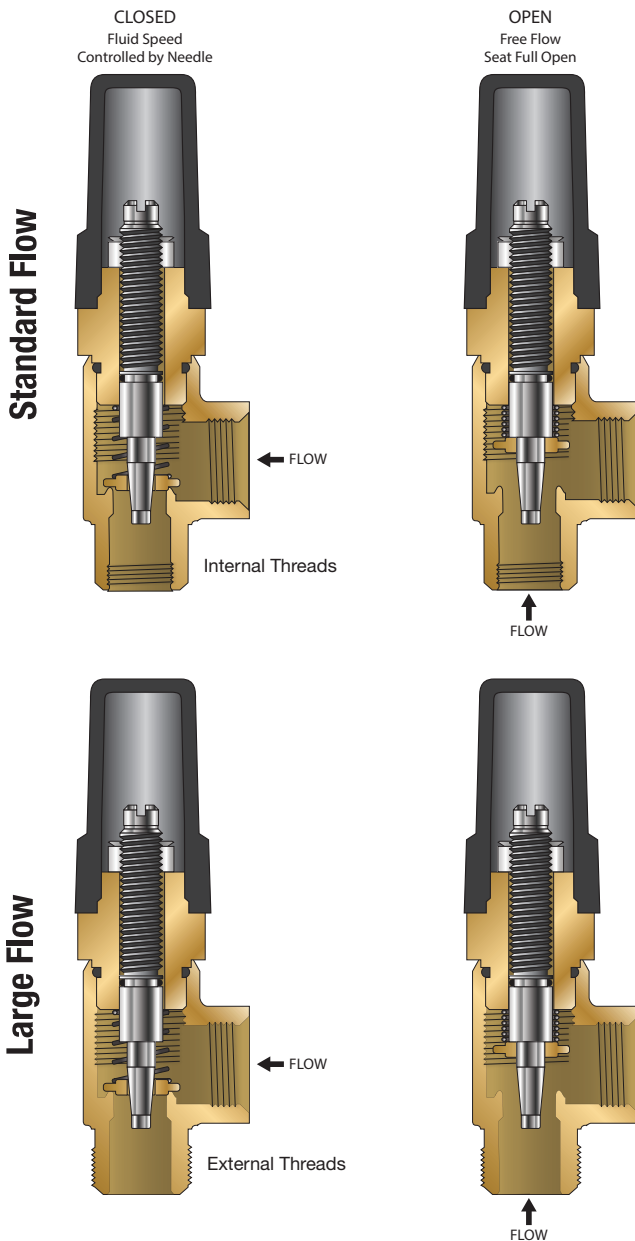

Specifications

Size: Standard Flow - 1/2" MNPT x 3/8" FNPT
 High Flow - 1/2" MxF NPT

Body Material: Lead Free Brass
 Stainless Steel (optional)

Seat: Lead Free Brass

Needle: Stainless Steel (304)

Elastomers: Buna-N (standard)

*The wetted surface of this product contacted by consumable water contains less than 0.25% of lead by weight.

LEAD FREE*

Model 50 Position Indicator

When specified as an option on a Control Valve, the Model 50 Position Indicator is installed in the topmost cover port of the Main Valve and allows for visual indication of valve position. The Model 50 is also very useful during valve start-up and troubleshooting procedures.

A stainless steel indicating rod threads into the tapped portion of the Main Valve stem and moves inside of a cylindrical Pyrex sight tube. The indicating rod travels up and down, following Main Valve stem movement. The housing protects the sight tube and indicating rod, and allows visibility on two sides. The screw driver operated test cock installed on the top of the Model 50 housing provides a controlled method of removal of air from the cover chamber during start-up or troubleshooting of the Main Valve.



Model LF50

Dimensions

Valve Size (in)	Dimension (in)
1¼ - 1½	7¾
2	4⅞
2½	4⅞
3	4⅞
4	5
6	5
8	5⅞
10	5⅞
12	7¼
14	7¼
16	7¼
18*	7¼
20*	7¼
24*	7¼

*Reduced Port

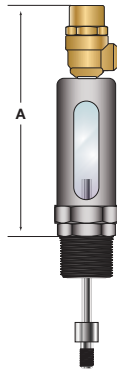

Specifications

Standard Material: Stainless Steel Housing and Body
Stainless Steel Indicating Rod

Lead Free Test Cock
Pyrex Sight Tube

Optional Material: Stainless Steel Test Cock

Pressure Rating: 400psi (27.6 bar)

*The wetted surface of this product contacted by consumable water contains less than 0.25% of lead by weight.

Model 50

Position Indicator

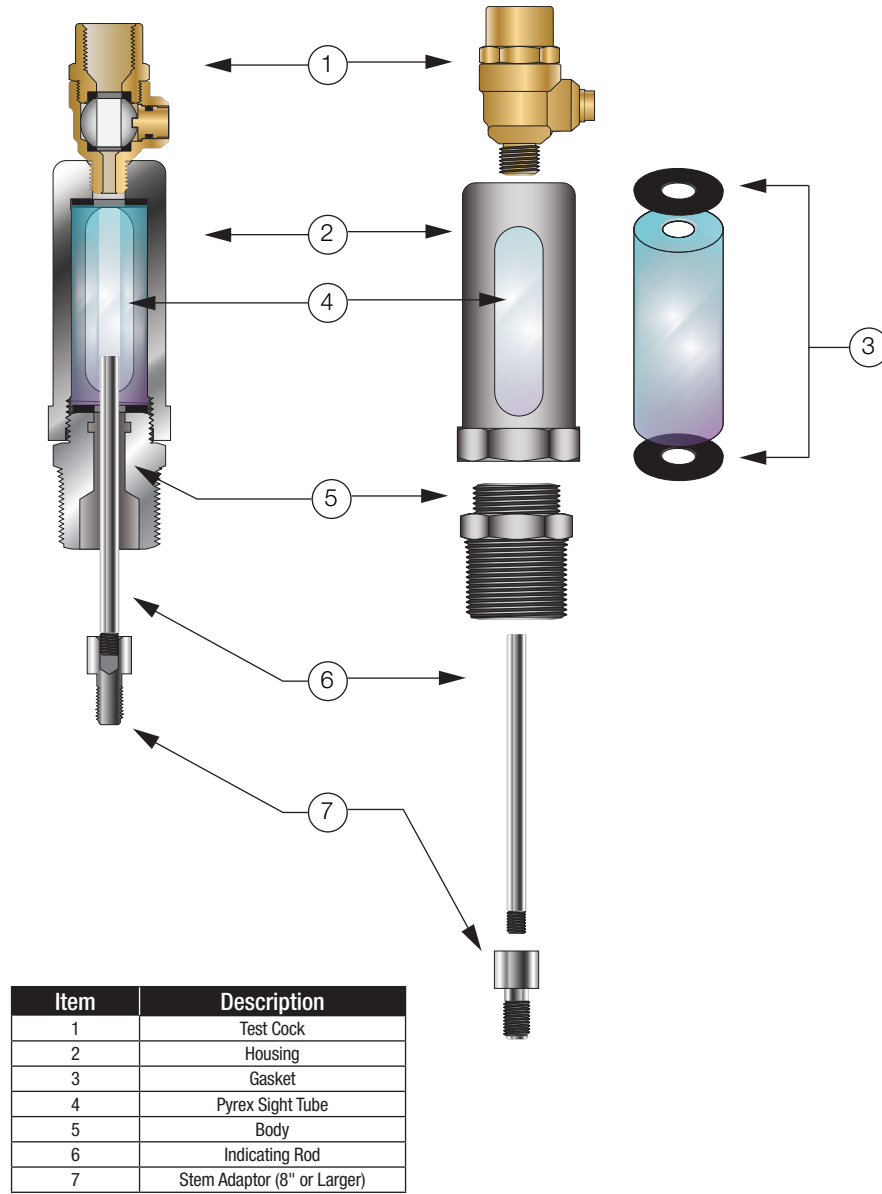

LEAD FREE*

Model 51

Single Limit Switch

The Model 51 Single Limit Switch provides visual indication of valve position, as well as remote electrical indication of "valve open" or "valve closed". The single pole double throw Micro-Switch can be connected to open or close an electrical circuit when the valve opens or closes.

The adjustable collar is normally set to contact the trip arm when the main valve is closed. The collar can be positioned on the stem by loosening the set-screw to actuate the switch at the desired point of valve travel.

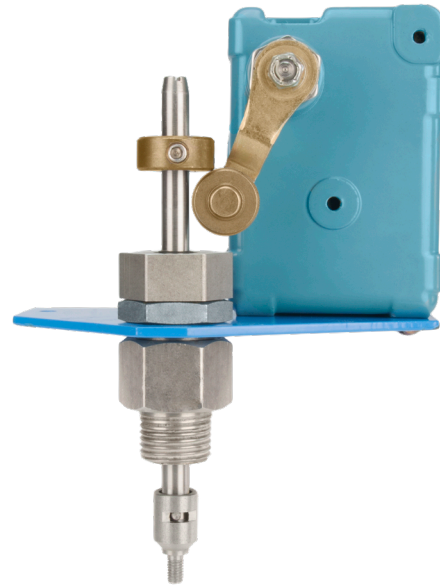

Model LF51

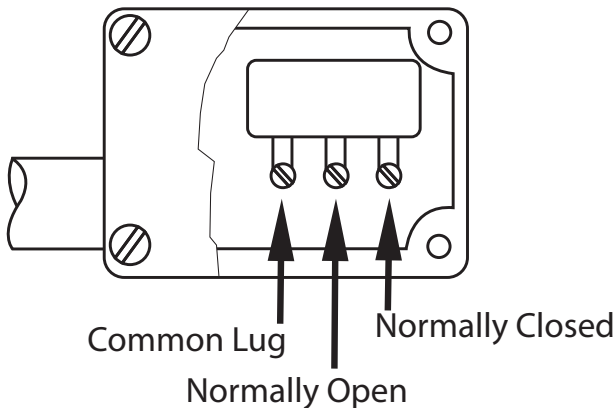

Single Pole Double Throw Switch

Specifications

Body Material: Stainless Steel

Elastomers: Buna-N (standard)
EPDM (optional)
Viton® (optional)

Enclosure: NEMA 1, 3, 4 and 13 General Purpose (standard)
NEMA 1,7 and 9 Explosion Proof (optional)

Electrical: Form C SPDT Switch
15 amp. 125, 250 or 480 VAC
½ amp. 125 VDC
¼ amp. 250 VDC
½" Conduit Connection

Viton® is a registered trademark of DuPont Dow Elastomers.

*The wetted surface of this product contacted by consumable water contains less than 0.25% of lead by weight.

Model 51

Single Limit Switch

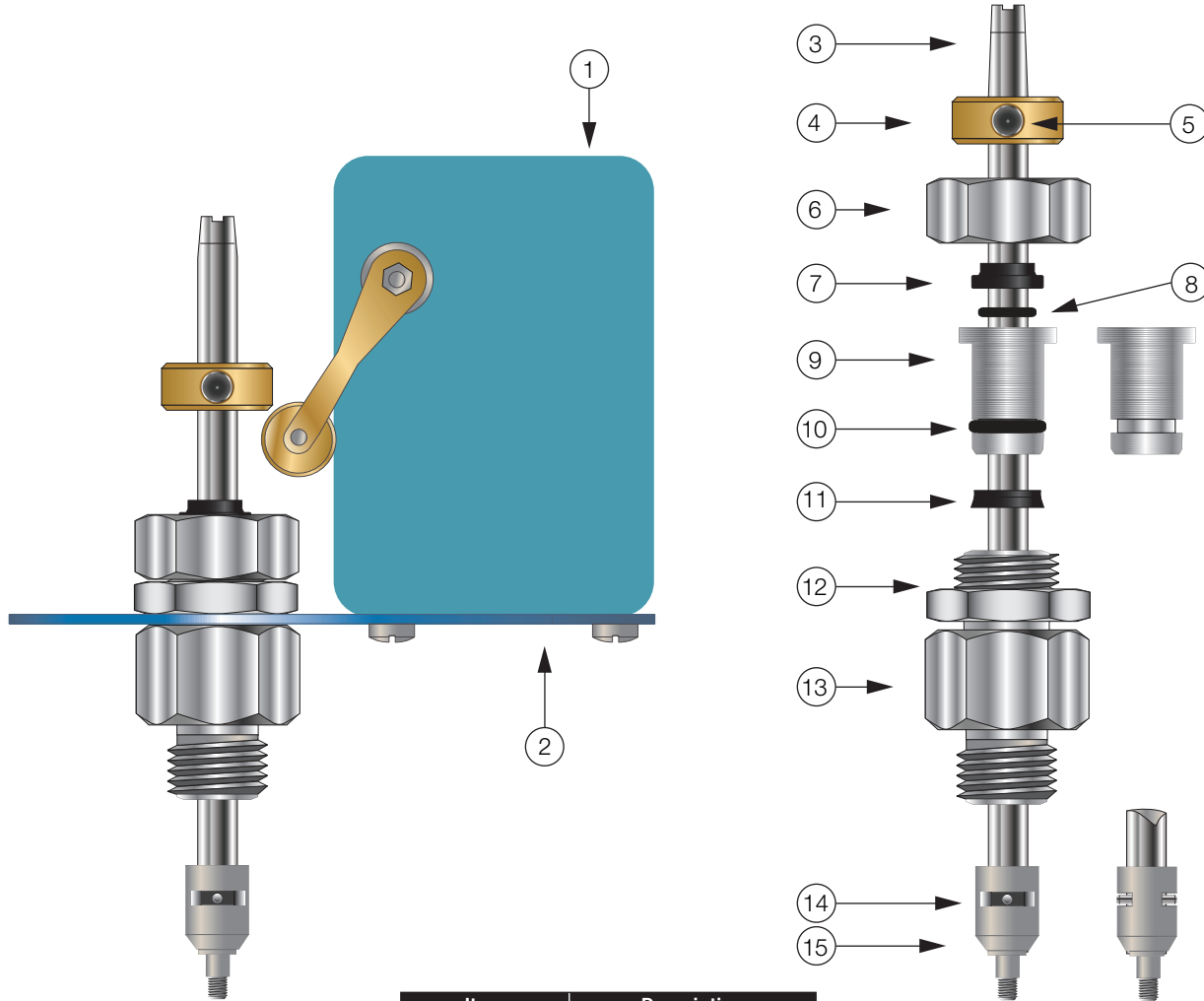

Item	Description
1	Limit Switch
2	Bracket
3	Stem
4	Trip collar
5	Set Screw
6	Cap
7	Wiper Ring*
8	O-Ring*
9	Guide
10	O-Ring*
11	Polypak*
12	Locknut
13	Body
14	Pin
15	Coupling

*Included in Repair Kit



USA: T: (978) 689-6066 • F: (978) 975-8350 • Watts.com
 Canada: T: (888) 208-8927 • F: (905) 332-7068 • Watts.ca
 Latin America: T: (52) 55-4122-0138 • Watts.com